

ECCC RECOMMENDATIONS - VOLUME 3 Part III [Issue 4]

**DATA ACCEPTABILITY CRITERIA AND DATA
GENERATION:
RECOMMENDATIONS FOR CREEP TESTING
OF POST EXPOSED (EX-SERVICE) MATERIALS**

blank page

ECCC RECOMMENDATIONS - VOLUME 3 Part III [Issue 4]

DATA ACCEPTABILITY CRITERIA AND DATA GENERATION: RECOMMENDATIONS FOR CREEP TESTING OF POST EXPOSED (EX-SERVICE) MATERIALS

PREPARED BY ECCC - WG1.1 - PEDS

Dr S Brett	RWE npower, UK (2001-)	
Dr L Buchanan	Mitsui Babcock, UK (2001-2004)	
Dr S Concari	CESI, Italy (2001-)	
Dr G L Cosso	Istituto Italiano della Saldatura, Italy (2003-)	
Dr G Fedeli	ENEL Produzione, Italy (1997-2001)	
Dr S Fenton	E.ON Power Technology, UK (1997-)	
Dr A Fleming	ETD, UK (2004-2005)	[Secretary]
Prof Dr E Gariboldi	Politecnico di Milano, Italy (1999-)	
Dr R Hales	ETD, UK (2001-2004)	[Secretary]
Mr J Hannigan	Mitsui Babcock, UK (2004-)	
Dr S R Holdsworth	ALSTOM Power, UK (1997-2001)	
Dr I Marcelles	Tecnom, Spain (2004-)	
Mr V Kanta	SKODA, Czech Republic (2001-)	
Dr Z Kubon	Vitkovice, Czech Republic (2001- 2004)	
Dr G Merckling	Istituto Scientifico Breda, Italy (1997-)	[Convenor]
Dr D G Robertson	ERA (1997-2001), ETD, UK (2005-)	[Secretary]
Prof R Sandstrom	KIMAB, Sweden (1999-)	
Dr P Seliger	Siempelkamp, Germany (1998-)	
Dr C Servetto	Istituto Italiano della Saldatura, Italy (1999-)	

EDITED BY: E GARIBOLDI, S. BRETT & G. MERCKLING

APPROVED



On behalf of ECCC

DATE 31/8/05

blank page

ABSTRACT

ECCC Recommendations - Volume 3 Part III gives

- Recommendations for the execution of conventional creep rupture tests suitable for the typical boundary conditions in which Post Exposed (ex-service) material is generally tested.
An overview of the needs for the recommendations introduces a series of tables, containing the minimum information required both for existing and new creep rupture test data. These tables also include the lowest common testing practice details and the recommended minimum requirements for future creep rupture testing of PE materials. When necessary, recommendations are then discussed separately. The recommendations for minimum material pedigree and testing practice information requirements, as defined by the PEDS subgroup of ECCC-WG1, are based on the results of the survey presented in Appendix 1. The tables of Appendix 1 summarise the responses to a Questionnaire circulated to European organisations involved in the generation and use of post exposed material creep data.
An appendix 4 (included since issue 4) recommends the decision making sequence to establish a typical suitable PE-material testing program, as it may be requested during a residual life assessment campaign.
- An overview on PE material specific testing techniques as currently proposed (conventional small scale creep testing, small punch testing, impression creep testing), including the actual status on testing practice harmonisation, comparability of results, applicability of their results for design or design verification purposes, time and cost benefits.

ECCC Recommendations Volume 3 Part III user feedback is encouraged and should be sent to:

Prof. E Gariboldi [Document Controller]
Politecnico di Milano
Dipartimento di Meccanica
Piazza L. da Vinci, 32
I-20133 Milano, Italy.
Tel: +39 02 2399 8224
Fax: +39 02 7063 8377
E-mail: elisabetta.gariboldi@polimi.it

ECCC may from time to time re-issue this document in response to new developments. The user is advised to consult the Document Controller for confirmation that reference is being made to the latest issue.

***This document shall not be published without the written permission of
the ECCC Management Committee***

blank page

Contents of Volume 3 Part III

1	Introduction AND EXECUTIVE SUMMARY	2
2	CONVENTIONAL CREEP TESTS ON POST EXPOSURE MATERIAL	3
2.1	Overview	3
2.2	Minimum Information for Creep Test Data on PE Material	4
2.2.1	Table 1: Minimum Material Pedigree Information for existing Creep Data on PE Materials	4
2.2.2	Table 2: Minimum Material Pedigree Information for NEW Creep Tests Data on PE Materials (Data generated after 1.1.2000)	4
2.2.3	Minimum Testing Information Requirements for existing Creep Tests Data on PE Materials	5
2.2.4	Table 4: Minimum Testing Information Requirements for NEW Creep Tests Data on PE Materials (Data generated after 1.1.2000)	6
2.2.5	Table 5: Recommended Minimum Requirements Mandatory for Future Creep Tests on PE materials (after 1.1.2000)	7
2.3	Minimum Requirements for Future Creep Tests on PE materials	10
2.3.1	Test machine	10
2.3.2	Loading	10
2.3.3	Displacement	11
2.3.4	Test piece	11
2.3.5	Atmosphere	13
2.3.6	Testing Program Set-Up (edited by G. Merckling and V.Kanta)	14
2.4	REFERENCES	15
3	Specific testing techniques for Post Exposure material creep behaviour investigation	16
3.1	Introduction	16
3.2	Small Scale Testing Techniques	17
3.3	Technical Aspects	17
3.3.1	Nature of the stress state/deformation mode	17
3.3.2	Modelling of test process	17
3.3.3	Equivalence of conventional test and small-scale test loads	18
3.3.4	Limitations of size	18
3.3.5	Specimen surface effects	18
3.3.6	Component surface effects	19
3.3.7	Reproducibility	19
3.3.8	Definition of specimen orientation	19
3.4	The Practical Application of Small Scale Testing	19
3.4.1	Where and how to sample	19
3.4.2	Access/extraction for sampling	19
3.4.3	Availability/costs of testing services	19
3.4.4	Availability/costs of sampling services	20
3.4.5	Use of the results	20
3.4.6	Acceptance of results by third parties	20
3.5	Examples of Application to Plant	20
3.5.1	Small Scale Conventional Testing – P22 Interconnector Pipe	20
3.5.2	Small Punch and Impression Creep Testing - Modified 9Cr (grade 91) Headers	22
3.6	Conclusions	25

Appendix 1 - ECCO-WG1-Peds Post Exposed (Ex-Service) Material Test Data Survey

Appendix 2 – Creep Testing On PE Materials: Literature Survey

Appendix 3 - Specific Creep Testing Techniques For PE Materials

App. 3a: Small Scale Conventional Creep Testing (G. Merckling)

App. 3b: Impression Creep (T. Hyde)

App. 3c: Small Punch Creep (Z. Kubon)

Appendix 4 – Schematic Guidance for the Set-Up of a Dedicated Testing Program for Post Exposure Material Creep Properties Determination (V. Kanta)

1 INTRODUCTION AND EXECUTIVE SUMMARY

The present Volume 3 part III addresses two aspects of testing on post exposure (ex service) materials:

- Chapter 2 deals with testing technique recommendations related to uniaxial tests on specimens mounted onto more or less conventional creep testing machines. In this case an extended overview on literature and on common laboratory practice forms the basis for the tables compiled, including minimum information required for a usable PE material creep data set, and for the recommendations issued, which want to be a guideline for effective and reliable testing in the mainframe of the particular boundary conditions, as usually encountered in residual life assessment and computation (acceptably reliable results obtained from small material samples in a short time without excessive costs compared to a complete residual life investigation procedure).
- Chapter 3 investigates the possibilities of producing credible creep behaviour predictions by using non conventional testing techniques, which have the main advantage to be not demanding in material quantity (small punch, indentation creep, small scale conventional creep). As the testing techniques are currently under assessment elsewhere, here a general overview from the appliers side is given, i.e. trying to find an answer on four fundamental questions:
 - What sort of data and information is produced by these techniques?
 - Are the available laboratory specific testing procedures equivalent?
 - How can data obtained by these techniques be used in design, i.e. mainly in residual life and/or damage status assessment?
 - What is the technical, temporal and economical benefit to the user?

2 CONVENTIONAL CREEP TESTS ON POST EXPOSURE MATERIAL

(edited by E. Gariboldi)

2.1 OVERVIEW

Creep, creep rupture or stress rupture testing of Post-Exposed (PE) materials is currently performed both with standard full-size testpieces and specimens of reduced size. Specimens which meet the requirements on specimen size stated by ECCC in [1] are considered full-size specimens. In particular, full-size specimens are those having $d_o \geq 5$ mm (where d_o is the diameter of the gauge length) and a reference length L_r greater than 3 times d_o (Definition of L_r is given in [1]). Reduced size specimens are classified into two groups: sub-size specimens (for which $3 \text{ mm} \leq d_o \leq 5 \text{ mm}$) and miniature specimens (for which $d_o < 3 \text{ mm}$). This distinction, based on specimen size, roughly corresponds to the possibility for destructively or non-destructively sampling PE materials from service components.

The main goal for testing PE material is to obtain information in order to carry out life assessment either of the component from which material was extracted or of other (often referred as 'comparable') components. For this reason, particular attention and care have to be paid not only to the execution of the test itself, but also to the sampling methods and to some basic characteristics of the extracted material (minimum material pedigree, i.e. operating condition, extraction location, microstructure...). Thus, a first series of recommendations concerning material sampling and characterization is given in Tables 1 and 2 for existing and new creep test data (the latter generated after 1.1.2000). Actually, the recommendations are requests for minimum material pedigree information, useful for assessing results of creep tests on PE material.

As far as the creep testing procedure is concerned, the minimum testing information requirements for existing creep data on PE materials are given in table 3a, while table 3b lists the lowest common testing practice specification for the same creep data. The minimum testing information requirements for new creep tests data on PE material, extended with respect to existing data, are given in Table 4. Further, it seems reasonable that the creep, creep rupture and stress rupture tests on full-size testpieces should meet the recommendations already stated by ECCC-WG1 [given in ref. 1]. However, since particular care on some features of creep testing have to be paid when dealing with PE materials, particularly when testpieces of reduced size are used, recommended minimum requirements are given in Table 5 for sub-size and miniature uniaxial creep specimens. These recommendations, mandatory for future creep testing, can be the same or different points of those given in [1]. When different from the corresponding in [1], points in Table 5 are written in bold italic type character. The third column of this table lists the corresponding column number in "Overview of creep rupture testing standards" in Appendix 1 of [1] and in some cases from Tables 5a and/or 5b in [1]. The reasons leading to the definition of the recommendations and comments on requirements, particularly where different from those stated by ECCC-WG1 [1] are given in the chapter of comments.

2.2 MINIMUM INFORMATION FOR CREEP TEST DATA ON PE MATERIAL

2.2.1 TABLE 1: MINIMUM MATERIAL PEDIGREE INFORMATION FOR existing CREEP DATA ON PE MATERIALS

Recommendation subject	2.2.1.1.1.1 Information requirement
Material Codes	Cast/heat number and/or material code used by testing laboratory
	Country code
Material type	Broad Classification
Product details	Product form
Chemical composition	Composition of the cast/heat Or of the product Or the nominal composition (if actual data not available)
Prior service details	Stress (nominal or average, if available, and if known, information of derivation)
	Temperature (nominal or average, if available, and if known, information's of derivation)
	Time spent at service conditions

2.2.2 TABLE 2: MINIMUM MATERIAL PEDIGREE INFORMATION FOR NEW CREEP TESTS DATA ON PE MATERIALS (DATA GENERATED AFTER 1.1.2000)

Recommendation subject	Information requirement
Material Codes	Cast/heat number
	Material code used by testing laboratory
	Country code
	Post expose material identifier ".PE"
Material Origin	Plant type (power, chemical, petro-chemical, pharma, other)
	Component
	Characteristic dimensions (give information or approx. overall size)
Material type	Broad classification
Product details	Product form
	Product dimensions
Heat treatment	Heat treatment details, temperature, time, cooling rate and coolant used
Chemical composition	Composition of the cast/heat Or of the product Or the nominal composition (if actual data not available)
Prior service details	Stress (nominal or average, if available, and information about method of derivation, if known)
	Temperature (nominal or average, if available, and information about method of derivation, if known)
	Time spent at service conditions
Supporting or Metadata Data Post-exposed	Hardness following service
	Hardness post test
	Microstructure following service
	Microstructure post test
	Metallurgical creep damage related to sample or representative sections
	Metallurgical creep damage related to component in significant area

2.2.3 MINIMUM TESTING INFORMATION REQUIREMENTS FOR existing CREEP TESTS DATA ON PE MATERIALS

Table 3a: Minimum Testing Information Requirements for EXISTING Creep Tests Data on PE Materials

Recommendation subject	Information requirement
Sampling details	Sampling position (needs reference to component geometry)
Test environment	Atmosphere used (if not air)
Test piece details	Test piece details (full-size, sub-size, miniature specimens)
	Type and dimensions of the notch (when used)
	Special/particular test piece form used (as drawing provided), eg. tubular, double diameter welded specimen, etc. (when applicable)
Test conditions	Temperature value and units
	Applied stress or initial stress (σ_0)
Test results	Test duration (all test types)
	Current test condition (all test types)
	Initial plastic strain (creep tests)
	Creep strain (ϵ_t) (creep tests)
	Total plastic strain (ϵ_p) (creep tests)

Table 3b: Lowest Common Testing Practice Specification for EXISTING Creep Tests Data on PE Materials

Category	Recommended point	Full-size and sub-size specimens (see Overview)	Miniature specimens (see Overview)
Testpiece	Diameter (d_0)	$d_0 > 5$ mm (full-size) $3 \leq d_0 < 5$ mm (sub-size)	$d_0 < 3$ mm
	Reference length (L_r)	$\geq 3 d_0$	≥ 10 mm
	Shape tolerance for d_0	± 0.04 mm	± 0.02 mm
	Measurement tolerance for d_0	± 0.02 mm	± 0.01 mm
Machine	Type	All, if load controlled	All, if load controlled
Temperature	Thermocouple	Base metal or rare metal	Base metal or rare metal
	Number of thermocouples	Sufficient	Sufficient
	Calibration	Error of thermocouple determined	Error of thermocouple determined
	Measurement equipment	Accuracy/resolution sufficient	Accuracy/resolution sufficient
	Permitted deviation	$\pm 3/4/6/8^\circ\text{C}$ up to 600/800/1000/1100 $^\circ\text{C}$ (measured)	$\pm 3/4/6/8^\circ\text{C}$ up to 600/800/1000/1100 $^\circ\text{C}$ (measured)
	Frequency of measurement	sufficient	Sufficient
Load	Laboratory ambient limits	Sufficiently constant	Sufficiently constant
	Permitted uncertainty	$\pm 0.01 \sigma_0$	$\pm 0.01 \sigma_0$
Displacement	Time of load application	As rapid as possible, without shock	As rapid as possible, without shock
	Total error – uninterrupted test	max [$\pm 0.0001L_r$, $\pm 10 \mu\text{m}$]	max [$\pm 0.0001L_r$, $\pm 5 \mu\text{m}$]
	Total error – interrupted test	max [$\pm 0.0001L_r$, $\pm 20 \mu\text{m}$]	max [$\pm 0.0001L_r$, $\pm 10 \mu\text{m}$]

2.2.4 TABLE 4: MINIMUM TESTING INFORMATION REQUIREMENTS FOR NEW CREEP TESTS DATA ON PE MATERIALS (DATA GENERATED AFTER 1.1.2000)

Recommendation subject	2.2.4.1.1.1.1.1.1 Information requirement	Information common to test series	Information unique to individual tests
Sampling details	Sampling method	X	X*
	Sampling location (need reference to component geometry)		X
	Sampling size	X	X
Test standard	State testing standard used or description of procedure	X	
Testpiece	Test piece details (full-size, sub-size, miniature specimens)	X	X*
	Test piece identifier		X
	Location and direction of test piece in products: Longitudinal (L), Transverse (Tr), Through Thickness (TT). When other terms are used, they should be accompanied by a descriptive diagram to show exact location and direction.		X
	Dimension and type of test piece tested:	X	X*
	Parallel length and diameter		X
	Gauge length used (Extensometer length)		X
	Reference length		X
	Type and dimensions of the notch (when used)		X
	Special features of test piece, e.g. combined plain and notched, extensometer location ridges, etc.	X	
	Special/particular test piece form used (as drawing provided), eg. tubular, double diameter welded specimen, etc. (when applicable)	X	
Test conditions	Atmosphere used (if not air)	X	
	Temperature value and units		X
	Temperature actual value and range achieved		X
	Heating rate and heating time		X
	Soak period before load applied		X
	Cooling rate or cooling time at the end of each campaign and/or end of test or state normal laboratory practice, e.g. cooled in still air	X	X*
	Laboratory temperature control limits	X	X*
	Thermocouple type used	X	X*
	Thermocouple calibration – errors (total error, systematic error, uncertainty)	X	X*
	Applied stress or initial stress (σ_0)		X
	Extensometer type (single or double sided)	X	X*
	Means of location of extensometer on specimen	X	X*
	Extensometer calibration details	X	X*
	Extensometer gauge length	X	X*
	Machine type	X	X*
	Number of strings in machine		X
	Number of test pieces in machine		X
	Number of test pieces per string		X
Load measurement system		X	
Load calibration	X	X*	
Test results	Test duration (all test types)		X
	Number of campaigns/interruptions (all test types)		X
	Current test condition (all test types): test continuing, (C) fractured (B), discontinued (DB)		X
	Elongation (A_u) (not for creep tests)		X
	Reduction of area (Z_u) (not for creep tests)		X
	Initial plastic strain (creep tests)		X
	Creep strain and/or total plastic strain (ϵ_p) at test duration (creep tests)		X

*: when different for various samples

2.2.5 TABLE 5: RECOMMENDED MINIMUM REQUIREMENTS MANDATORY FOR FUTURE CREEP TESTS ON PE MATERIALS (AFTER 1.1.2000)

Category	Recommended point	Col. No in [1] - Appendix 1	Full-size specimens	Sub-size specimens	Miniature specimens	Paragraph in the chapter on minimum requirements
Test procedure		2	Uninterrupted and interrupted (u.t. and i.t.)	Uninterrupted and interrupted (u.t. and i.t.)	Uninterrupted and interrupted (u.t. and i.t.)	
Test machine	Machine Type	5-7	All, if load controlled	Dead weight or lever type machine	Dead weight machine	1.1
	Machine strings	3	Single Machine (1 specimen), Multi Machine (1 string, > 1 specimen), Multi Specimen Machine (> 1 string and each string with more than 1 specimen)	Single Machine (1 specimen), Multi Machine (1 string, > 1 specimen), Multi Specimen Machine (> 1 string and each string with more than 1 specimen)	Single Machine (1 specimen), Multi Machine (1 string, >1 specimen), Multi Specimen Machine (<1string) A single specimen per string is preferable.	1.2
Temperature	Thermocouple	13	New base metal to <400°C or <1000h else rare metals to IEC 584-2, Class1	New base metal to <400°C or <1000h else rare metals to IEC 584-2, Class1	New base metal to <400°C or <1000h else rare metals to IEC 584-2, Class1	
	Number of thermocouples	14	2-3/testpiece for SM 1-2/testpiece for MM 1/ heating zone for MSM (with regular control measurements)	2/testpiece for SM 1-2/testpiece for MM 1/ heating zone for MSM (with regular control measurements)	2/testpiece for SM 1-2/testpiece for MM 1/ heating zone for MSM (with regular control measurements) 1/ testpiece for MSM (when 1 testpiece/ string is used)	
	Thermocouple calibration	15	By method traceable to Internat. Unit	By method traceable to Internat. Unit	By method traceable to Internat. Unit	
	Thermocouple re-calibration	Table 5a/b in [1]	Base metal: only new Rare metal: in situ after 4 yr (<600°C), 2 yr (600-800°C), 1yr (800-1350°C) or at the end of the test when scheme times exceeded	Base metal: only new Rare metal: in situ after 4 yr (<600°C), 2 yr (600-800°C), 1yr (800-1350°C) or at the end of the test when scheme times exceeded	Base metal: only new Rare metal: in situ after 4 yr (<600°C), 2 yr (600-800°C), 1yr (800-1350°C) or at the end of the test when scheme times exceeded	

Category	Recommended point	Col. No in [1] - Appendix 1	Full-size specimens	Sub-size specimens	Miniature specimens	Paragraph in the chapter on minimum requirements
Temperature (continued)	Measurement equipment	11 12 -	Tolerance: $\pm 0.5\text{ }^{\circ}\text{C}$ Resolution: $\pm 0.1\text{ }^{\circ}\text{C}$ Re-calibration: 1 yr	Tolerance: $\pm 0.5\text{ }^{\circ}\text{C}$ Resolution: $\pm 0.1\text{ }^{\circ}\text{C}$ Re-calibration: 1 yr	Tolerance: $\pm 0.5\text{ }^{\circ}\text{C}$ Resolution: $\pm 0.1\text{ }^{\circ}\text{C}$ Re-calibration: 1 yr	
	Heating /soaking time	28	u.t.: heating + soaking time $\leq 24\text{ h}$ i.t.: heating time $\leq 4\text{ h}$, soaking time $\leq 3\text{ h}$	u.t.: heating + soaking time $\leq 24\text{ h}$ i.t.: heating time $\leq 4\text{ h}$, soaking time $\leq 3\text{ h}$	u.t.: heating + soaking time $\leq 24\text{ h}$ i.t.: heating time $\leq 4\text{ h}$, soaking time $\leq 3\text{ h}$	
	Permitted temperature tolerance	10	$\pm 3/4/5/6/7/8\text{ }^{\circ}\text{C}$ up to 600/800/1000/ 1100/1200/1350 $^{\circ}\text{C}$ (total)	$\pm 3/4/5/6/7/8\text{ }^{\circ}\text{C}$ up to 600/800/1000/ 1100/1200/1350 $^{\circ}\text{C}$ (total)	$\pm 3/4/5/6/7/8\text{ }^{\circ}\text{C}$ up to 600/800/1000/ 1100/1200/1350 $^{\circ}\text{C}$ (total)	
	Frequency of temperature measurement	18	Sufficient recording	Sufficient recording	Sufficient recording	
	Laboratory ambient limits	23	$\pm 3\text{ }^{\circ}\text{C}$ (u.t., creep laboratory) $\pm 2\text{ }^{\circ}\text{C}$ (i.t., inspection laboratory)	$\pm 3\text{ }^{\circ}\text{C}$ (u.t., creep laboratory) $\pm 2\text{ }^{\circ}\text{C}$ (i.t., inspection laboratory)	$\pm 3\text{ }^{\circ}\text{C}$ (u.t., creep laboratory) $\pm 2\text{ }^{\circ}\text{C}$ (i.t., inspection laboratory)	
Loading	Tolerance of load	21	$\pm 0.01\ \square_0$	$\pm 0.01\ \square$	$\pm 0.01\ \square$	2.1
	Load calibration standard	8	All acceptable if fulfil requirements on load accuracy	All acceptable if fulfil requirements on load accuracy	All acceptable if fulfil requirements on load accuracy	
	Pre-loading	23	$\leq 10\%$ of applied load (preferable) or first loading at room temperature	$\leq 10\%$ of applied load	$\leq 10\%$ of applied load	2.2
	Time of load application	22	$\leq 10\text{ min.}$, without shock	$\leq 10\text{ min.}$, without shock	$\leq 10\text{ min.}$, without shock	
	Allowable bending	24	Minimized, future goal $< \pm 20\%\ \square_0$	Minimized, future goal $< \pm 20\%\ \square_0$	Minimized, future goal $< \pm 20\%\ \square_0$	2.3
	Allowable torsion	24	Minimized	Minimized	Minimized	2.4
Displacement	Means for strain measurement	39	For u.t.: extensometer For i.t. : microscope	For u.t.: extensometer fixed to the specimen or double-sided external displacement measurement equipment For i.t. : microscope	For u.t.: double-sided external displacement measurement equipment For i.t. : microscope	3.1
	Measurement	38	Average from two sides	Average from two sides	Average from two sides	
	Total error	Table 5a in [1] Table 5b in [1]	For u.t.: max $[\pm 0.01\ \square_{L_r}, \pm 3\ \square_{m}]$ For i.t.: max $[\pm 0.01\ \square_{L_r}, \pm 10\ \square_{m}]$	For u.t.: max $[\pm 0.01\ \square_{L_r}, \pm 3\ \square_{m}]$ For i.t.: max $[\pm 0.01\ \square_{L_r}, \pm 10\ \square_{m}]$	For u.t.: max $[\pm 0.01\ \square_{L_r}, \pm 3\ \square_{m}]$ For i.t.: max $[\pm 0.01\ \square_{L_r}, \pm 10\ \square_{m}]$	3.2

Category	Recommended point	Col. No in [1] - Appendix 1	Full-size specimens	Sub-size specimens	Miniature specimens	Paragraph in the chapter on minimum requirements
Testpiece	Specimen material	-	Homogeneous or weld extended	Homogeneous or weld extended	Homogeneous or weld extended	
	Diameter (d_0)	31	≥ 5 mm	$3 \leq d_0 < 5$ mm Cross section area should contain more than 50 grains	$d_0 < 3$ mm Cross section area should contain more than 50 grains	4.1
	Shape tolerance for d_0	33	± 0.02 mm ($5 < d_0 \leq 10$ mm)	± 0.01 mm	± 0.01 mm	4.2
	Measurement accuracy for d_0	34	± 0.005 mm ($5 < d_0 \leq 10$ mm)	± 0.003 mm	± 0.002 mm	4.3
	Reference length (L_r)	36	$\geq 3 d_0$ (preferred $\geq 5 d_0$), $L_r \leq 1.1 L_c$	$\geq \max [3 d_0, 10 \text{ mm}]$	≥ 10 mm	4.4
	Length tolerance ($\square L_0$)	Table 5a/b in [1]	$\pm 0.01 L_0$	$\pm 0.01 L_0$	$\pm 0.01 L_0$	
	Transition radius (R)	32	$d_0/2 \geq R \geq d_0/4$	$1.5 d_0 \geq R \geq d_0/4$	$1.5 d_0 \geq R \geq d_0/4$	4.5
	Material of the weld extended ends	-	If possible, the same material of the gauge length	If possible, the same material of the gauge length	If possible, the same material of the gauge length	4.6
Length of PE material in weld extended testpieces	-	The extensometer gauge length (L_c) should not be affected by microstructural changes resulting from welding the gripping ends.	The extensometer gauge length (L_c) should not be affected by microstructural changes resulting from welding the gripping ends.	The extensometer gauge length (L_c) should not be affected by microstructural changes resulting from welding the gripping ends.	4.7	
Test results	Time tolerance	27	± 0.01 t	± 0.01 t	± 0.01 t	
Atmosphere	Atmosphere type	4	Air for normal cases inert gas (argon) or vacuum when oxidation in air is excessive	Air for normal cases inert gas (argon) or vacuum when oxidation in air is excessive	Air for normal cases inert gas (argon) or vacuum when oxidation in air is excessive	5.1
	Vacuum level (if tests in vacuum)	-	Not defined 'a priori'	Not defined 'a priori'	Not defined 'a priori'	5.2
	Static/flowing gas (if tests in argon)	-	Not defined 'a priori'	Not defined 'a priori'	Not defined 'a priori'	5.2
	Procedure for operating in atmosphere		Not defined 'a priori'	Not defined 'a priori'	Not defined 'a priori'	5.2

2.3 MINIMUM REQUIREMENTS FOR FUTURE CREEP TESTS ON PE MATERIALS

2.3.1 TEST MACHINE

2.3.1.1 MACHINE TYPE

For both sub-size and miniature specimens the small loads to be applied and controlled favour the use of dead weight or lever type machine. The loads required for creep tests, particularly for miniature specimens having a reduced cross sectional area, can be more easily achieved when direct load machines are used. In this case also errors on the length of the lever arm are avoided and better alignment guaranteed.

2.3.1.2 MACHINE STRINGS

The use of a single specimen for each string in multi machines and multi specimen machines is preferable for mini-specimens in order to attain and satisfy better alignment, load and bending/torsion requirements.

2.3.2 LOADING

2.3.2.1 TOLERANCE OF LOAD

Due to the reduced cross sectional area of sub-size and miniature specimens with respect to full-size specimens, the same tolerance on the applied load expressed as a maximum percentage of applied stress corresponds to greater accuracy of the loading apparatus of the creep machine.

2.3.2.2 PRE-LOADING

The same maximum pre-load recommended for full-size specimens should be used for testpieces of reduced size. The reason for application of pre-loading remains the same, i.e. minimization of non-linear effects on strain measurements. This minimization should be carefully considered in the cases where the strain measurement system is not directly fixed to the specimen, as in some testing practices for reduced size specimens, in particular for miniature specimens (see 3.1). A maximum amount of 10% pre-load corresponds to a very reduced load when miniature specimens are performed. When lever-arm or dead-weight machines are used, the minimum applied load when no load pan is applied should be checked to result in pre-loading stress lower than 10% σ_0 .

2.3.2.3 ALLOWABLE BENDING

Local excesses of applied stress as well as errors on rupture time and on other test results can be induced by bending effects. In the case of non-axial loading, the local increase in stress ($\Delta\sigma_b$) is related to applied stress (σ), misalignment (e), specimen radius (r) and stress exponent of the material (n) by the following relation [2]

$$\Delta\sigma_b = 4 \sigma e r^{-2} r^{1/n}$$

Therefore, the effect of bending increases as the specimen size is reduced and stress exponent increased. Further, the effects of bending on the results of creep testing can be of greater importance when a low-ductility material is being tested (as it can occur when ex-service materials are tested).

Some modifications of loading apparatus are proposed in the literature to limit bending effects [3-5]. Despite the relative importance of bending stresses on small size specimens, no particular maximum bending value has been reported for them in the examined literature. As for the load accuracy, the recommended tolerance on bending stress could be maintained as recommended in [1] for full-size testpieces: bending has to be minimized and

a bending stress lower than 20% σ_o has to be considered as a future goal. In order to maintain this tolerance, a more accurate alignment of the loading string and of the gripping ends will be needed. Elastic bending stresses could be measured by means of strain gauges attached on a specimen of the same geometry as those to be tested.

2.3.2.4 ALLOWABLE TORSION

No particular value for minimization of torsion stresses has been found in the examined standards, papers or laboratory practices. In the case of specimens of reduced size, particularly miniature specimens, torsion forces such as those arising from gripping could result in torsion stresses of importance. Due to the usual precautions against torsion taken when designing creep machines, no maximum value for torsion stresses has been recommended for full-size specimens [1]. When only axial applied stress σ_o and torsion stress τ are present, the Von Mises equivalent stress σ_e is $(\sigma_o^2 + 3\tau^2)^{0.5}$ and maximum principal direction does not coincide with the specimen longitudinal axis. Notwithstanding this latter difference with the case in which only bending effects are present, the same maximum value for σ_e (i.e. $1.2\sigma_o = \sigma_o + \sigma_{\text{bending max}}$) can be desirable. This results in a maximum torsion stress of $0.38 \sigma_o$ that can be a future goal for the upper limit to torsion stresses. At present a minimization of torsion stress is recommended for each specimen type.

The first step that can be proposed in view of minimization of torsion stresses is their measurement, to be performed on specimen of the same geometry as those to be tested.

2.3.3 DISPLACEMENT

2.3.3.1 MEANS FOR STRAIN MEASUREMENT

The preferable strain measurement system consists of double-sided extensometers directly fixed to the gauge length of the specimen. When miniature specimens (and sometimes sub-size specimens) are used, a different strain measurement system is commonly adopted. It is a double-sided displacement measurement system (for example a couple of LVDT each with a displacement transfer system) measuring the relative displacement between a machine part fixed to the upper end of the specimen and another machine part fixed to the bottom end of the testpiece. In these cases the measured displacement corresponds to the sum of elongation of testpiece and of elongation/displacements of the upper and lower machine parts between the displacement measurement points. Thus, the PE material strain should be approximately evaluated by means of mathematical models considering both material behaviour, specimen geometry (considering the reference length of the specimen, see. [1]) and the compliance of the machine parts. The above models became more complicated, and results less accurate, as the number of specimens is increased in multi-machines or multi-specimen machines (preferably to be avoided for miniature specimens).

2.3.3.2 TOTAL ERROR

When using sub-size specimens, their limited reference length (L_r) as well as the reduced displacements to be measured make necessary the use of displacement measurement devices having a reduced measurement range and a greater accuracy.

When the displacement measurement system is not directly fixed on the specimen the displacement allowed tolerance refers to the displacement tolerance reduced to the reference length.

2.3.4 TEST PIECE

2.3.4.1 DIAMETER

A minimum average number of grains should be required since “a small number of grains in the specimen cross section, or preferred orientation of grains due to fabrication conditions, can have a pronounced effect on the test results» [ASTM E139-83 (reapproved 1990)]. The

recommended minimum value of 50 grains (as an order of magnitude) was proposed in literature [3]. In the case that the above requirement on the minimum number of grains in the specimen cross section could not be met, this fact has to be taken into consideration when handling the results of creep tests.

2.3.4.2 SHAPE TOLERANCE FOR D_0

The shape tolerance on d_0 can be reduced with respect to full-size specimens, according to the surveyed current laboratory practice (see Annex 1 - Overview on testing methods for the generation of PE material test data).

2.3.4.3 MEASUREMENT ACCURACY FOR D_0

The recommended measurement accuracy for d_0 was reduced to ± 0.003 mm in the cases of sub-size specimens and to ± 0.002 mm in the cases of miniature specimens, in order to better evaluate the applied stress. In this way (see table below) errors on the applied stress $\Delta\sigma$ due to the maximum permitted error on the measurement of diameter are the same ($0,002 \sigma_0$) for specimens having the minimum diameter of each test piece type: i.e. a full-size specimen of 5 mm diameter, a sub-size specimen of 3 mm diameter and a miniature specimen of 2 mm diameter (a typical diameter adopted for miniature specimens).

Diameter d_0	Tolerance on d_0	$\Delta\sigma/\sigma_0$
10	0,005	0,0010
5	0,005	0,0020
3	0,005	0,0033
2	0,005	0,0050
5	0,003	0,0012
3	0,003	0,0020
2	0,003	0,0030
5	0,002	0,0008
3	0,002	0,0013
2	0,002	0,0020

2.3.4.4 REFERENCE LENGTH

The minimum L_r/d_0 ratio was fixed to 3 for sub-size specimens (as for full-size specimens). In any case, the reference length should not be lower than 10 mm, taking into account handling needs. The recommended lower limit on L_r for miniature specimens is 10 mm, independently on the gauge diameter (this always corresponds to $L_r/d_0 > 3$).

2.3.4.5 TRANSITION RADIUS

As d_0 decreases, passing from sub-size to miniature specimens, it seems not reasonable to propose transition radius R proportional to d_0 . A reduction of R would correspond to increased difficulties in accurate machining of the transition radius region of the specimens. The recommended range of transition radius for full-size specimens [1], of common practice in most creep laboratories, was proposed in [1] in order not to exceed $L_r/L_c = 1.1$. For sub-size and miniature specimens the minimum R/d_0 should reasonably remain 0.25, while the maximum R/d_0 ratio could be raised to 1,5 (for example a transition radius R of 3 mm for $d_0 = 2$ mm) while maintaining the upper limit to L_r/L_c .

It should also be considered that some shapes of sub-size and miniature specimens have been proposed that can not meet the above requirements on transition radius, for example when having conical ends [5].

2.3.4.6 MATERIAL OF THE WELD EXTENDED ENDS

Weld-extended specimens are used when the amount of PE material is limited. At the same time a certain degree of material homogeneity for creep specimens is desirable. The

material used for the gripping ends was sometimes [3] defined as identical (without any further explanation of the term «identical») to that of gauge length. It seems reasonably useless to use the same PE material (there would be no reason to prepare weld-extended specimens!). On the other hand, even virgin material from the same heat of PE material could have a different behaviour. Further, the presence of the HAZ (see 4.7 below) in the gripping ends could lead to a different material behaviour in such a region. Thus, the recommendation to use a material having the same nominal composition of PE material for gripping ends seems reasonable.

2.3.4.7 LENGTH OF PE MATERIAL IN WELD EXTENDED TEST PIECES

Weldments of the raw cylinders of PE material to gripping ends of greater diameter are usually Laser or Electron Beam weldments in order to minimize the microstructure changes due to local heating effects. However, PE material within a certain distance from the weldment is microstructurally affected by the heating cycle of the welding operation (Heat Affected Zone). In order to consider the creep behaviour of the PE unaltered material, the extensometer gauge length should lay completely within the base (unaltered) material. In this way no problem in the determination of reference length L_r can arise because of the presence of materials having different material behaviour. The extension and location of HAZ could for example be detected via microindentation hardness tests on raw specimens (to be carried out after the welding operations, prior to the final machining of the specimen) [3].

When sub-size or miniature weld-extended specimens are tested with an external displacement measurement system the presence of materials of different mechanical behaviour both in the weld zone and in the gripping ends makes the determination of strain in the gauge length become more complicated.

2.3.5 ATMOSPHERE

2.3.5.1 ATMOSPHERE TYPE

The use of inert gas (argon) or vacuum is usually taken into account in laboratory practice when oxidation effects are not negligible, particularly when small-size testpieces are used. The above environments are also sometimes used to avoid excessive surface material alteration (for example material softening). Other particular atmospheres can of course be used when creep testing is aimed at studying the interaction between the material and that particular environment.

There is a need to define a value of maximum oxidation of the crept specimens above which the test results can not be considered acceptable and the use of inert gas or of vacuum environment is recommended. In order to give a valid recommendation independently on temperature, material and test time, a simple definition of a maximum admitted geometric parameter for carrying out tests in air can be fixed. The parameter is the A_{ox}/A_o ratio between the oxide layer area A_{ox} (i.e. layer thickness * specimen perimeter) and the cross section area A_o (considered at the beginning of the test) [6]. Under the following hypotheses:

- homogeneous oxidation,
- small thickness of the oxide layer compared to specimen diameter,
- no contribution of the oxide layer to the load bearing capacity of the specimen,

the above A_{ox}/A_o ratio corresponds to $\Delta\sigma_0/\sigma_0$.

The table below lists the thickness t of the oxidized external layer of metal giving rise to stress increments ($\Delta\sigma_0/\sigma_0$) in cylindrical testpieces of different diameter d_0 . The oxide thickness at the end of the test could be estimated on the basis of oxide growth rate of PE material at test temperature and of a foreseen test duration.

Diameter d_0	$\Delta\sigma_0/\sigma_0$ (%)	Oxide thickness t (mm)
10	10	0.250
5	10	0.125
3	10	0.075
2	10	0.050
10	5	0.0125
5	5	0.063
3	5	0.038
2	5	0.025
10	2	0.050
5	2	0.025
3	2	0.015
2	2	0.010
10	1	0.025
5	1	0.013
3	1	0.008
2	1	0.005

A maximum increase in stress level at the end of the tests of 1% is too restrictive since it corresponds to a very thin oxide layer, particularly for sub-size and miniature specimens. A more suitable value of 5% at the end of tests could be fixed as the upper limit to consider oxidation effects to be negligible. Further and more accurate investigations on the effect of the evolution of the oxide layer on the increment of the stress level and thus on the results of creep tests should be carried out in order to give a more suitable recommendation on tolerable oxidation.

2.3.5.2 DETAILS ON THE ATMOSPHERE AND ON PROCEDURES FOR OPERATING IN ATMOSPHERE

The reduction of environmental effects by means of testing in particular atmospheres was experienced to have sometimes negative effects, related to the testing procedure. The case of decarburization of a low alloy piping steel reported by McCarthy [7] (explained as a result of the presence of residual moisture inside the chamber containing argon) is the example usually cited in the literature. In the mentioned case the negative effects were eliminated using a vacuum chamber maintained at $6 \cdot 10^{-3}$ mbar. Other environment and test procedures are currently followed. Some laboratories perform creep tests in inert static argon, but after reaching a high vacuum level in the chamber (10^{-6} mbar is the value reported in [3]) with the aim of eliminating the presence of moisture inside the chamber. Another, quite common, practice is the use of a gas chamber where a stream of argon is slowly flowing.

Since the main reason leading to the use of argon or vacuum is the prevention of excessive oxidation, and since at present there is no clear view on the testing procedures to be used, at the moment every environment and test procedure that guarantees the minimization of oxidation during the test can be used when oxidation of specimens tested in air is excessive (see paragraph 5.1).

2.3.6 TESTING PROGRAM SET-UP (EDITED BY G. MERCKLING AND V.KANTA)

The set-up of a suitable testing program for the determination of remnant creep properties of post exposure material is conditioned by several technical and non technical aspects. Among these the following are generally intended to be essential:

- Material saving, because only a minimum amount of material can usually be sampled from the component in service without requiring heavy repair: The selection of suitable testing techniques and the minimisation of the number of tests becomes mandatory.
- Minimisation of component damage due to sampling, but sampling material meaningful to the testing and to the residual life assessment.
- Production of tests in a useful timescale: i.e. test set-up and program need to compromise between useful engineering duration and plant re-start-up requirements.
- Usefulness and meaningfulness of results for Residual Life Assessment
- Sampling and testing costs need to match the Residual Life Assessment economical budgets.

In order to meet the above requirements, appendix 4 includes a flow-chart, meant to assist and optimise the testing program for post exposure material testing during a Residual Life Assessment campaign.

2.4 REFERENCES

1. ECCC Recommendations Volume 3, Part I, 2001, «Data acceptability criteria and data generation: Generic recommendations for creep, creep rupture, stress rupture and stress relaxation data», (Issue 5), edited by J. Granacher & S.R. Holdsworth, Published by ERA Technology Ltd, Leatherhead.
2. J.D. Parker, «The effect of specimen size on creep behaviour», *Rivista Italiana della Saldatura*, 48 (1996), 6, p. 609-617.
3. A. Garzillo, C. Guardamagna, L. Moscotti, L. Ranzani. «A technique for the residual life assessment of high temperature components based on creep rupture testing on welded miniature specimens», *Int. J. Pres. Ves. & Piping*, 66 (1996), 223-232.
4. E. Lucon, S. Tettamanti, L. Ranzani «Le prove meccaniche su campioni miniaturizzati: finalità, tecniche e affidabilità dei risultati», Workshop «Prove meccaniche sui materiali metallici», Milan, 10 Dec. 1997.
5. V. Bicego, M. Certo, C. Sanpietri, F. Bregani, «Non destructive material creep damage evaluation in service exposed components: ENEL experience»,
6. N. Roy, R.N. Ghosh, «Modelling effects of specimen size and shape on creep of metals and alloys. *Scripta Materialia*, 36 (1997), 12, pp. 1367-1372.
7. P. McCarthy, J.M. Brear, «Successful miniature specimen testing: a case study» *Proc. fifth Int. Conf. «Creep and Fracture of Engineering Materials and Structures»*, Swansea, 28/3-2/4 1993, pp. 661-670.
8. J.D. Parker, B. Wilshire, «Non-destructive life assessment of High Temperature Components and Weldments», *Int. J. Pres. Ves. & Piping*, 50 (1992), 337-347
9. B. Billi, D. D'Angelo, M. Livraghi, G. Maciga, «Structural integrity assessment and lifetime predictions of operating thermal power pipelines», presented at *Int. Symp. on Prediction of residual lifetime of constructions operating at high temperature*, The Hague, 3-4 Nov. 1977
10. D. Mercaldi, J.D. Parker, «Material sampling for rotor evaluation», *EPRI Conference «Assessment of turbine generators»*, Charlotte (North Carolina), 1989.

3 SPECIFIC TESTING TECHNIQUES FOR POST EXPOSURE MATERIAL CREEP BEHAVIOUR INVESTIGATION

(edited by S. Brett)

3.1 INTRODUCTION

Power generating companies, and other operators of ageing power plant, have an on-going requirement to ensure the continuing structural integrity of their high temperature components by remnant life assessment. Similar requirements arise in other industries such as petrochemical and aerospace. This may involve a component-specific assessment which in turn requires component-specific materials creep data. Small-scale creep testing has the potential to allow for the acquisition of specific materials data for this purpose, without the associated penalty of significant material removal. The samples would generally be sufficiently small to be obtainable without jeopardising the structural integrity of plant components. Larger scale sampling brings with it the need for the structural justification, or even the repair, of the area sampled.

The ultimate goal of small-scale creep testing is to be able to produce data equivalent to, and readily interchangeable with, those obtained by full-scale conventional creep testing. In some cases rupture life is the main property of interest while in other cases, particularly where useful life is limited by dimensional tolerance, creep strain rate is the critical factor. To achieve practical application, small-scale testing must produce creep strain data and rupture lives either the same as, or convertible into, those obtained in the conventional test under equivalent testing conditions.

Short of this goal, however, a reliable method of comparing the creep behaviour of differing components could provide benefits to plant operators. For example, if small-scale testing could reliably rank different sampled materials in the correct order of their conventional creep strength, this information could be used for eg prioritisation of inspection, repair etc.

Assuming that the technical requirements can be met satisfactorily, a further goal for the plant operator would be the promotion of such small-scale tests into a universally accepted methodology, with the emergence of an agreed standard technique. This would lead to acceptance of the approach by eg customers, insurers, boiler inspectors, regulatory bodies, etc, The techniques could be incorporated into European standards and could, in principle, become the primary method of establishing the remnant life of ageing plant.

3.2 SMALL SCALE TESTING TECHNIQUES

Three types of small-scale test are currently available:

Small-scale “conventional” creep

This is essentially a scaled down version of conventional testing utilising specimens of similar geometry loaded in a similar manner to produce creep rates equivalent to those of obtained from larger specimens. A more detailed description can be found in Appendix 1.

Impression creep

This technique utilises indentation at high temperature to produce a constant deformation rate from which a creep strain rate can be derived. Further details can be found in Appendix 2.

Small punch creep

This technique uses a punch arrangement to deform flat disc specimens to failure at high temperature, producing a deformation curve similar to that of a conventional creep test. Further details are provided in Appendix 3.

The three test methods are compared in the following sections where the similarities and differences between them are highlighted.

3.3 TECHNICAL ASPECTS

3.3.1 NATURE OF THE STRESS STATE/DEFORMATION MODE

Conventional small-scale creep testing can be considered to be equivalent to full size creep testing. Small punch testing is essentially a bend test. Impression creep subjects the test specimen to compression. Conventional small-scale and small punch tests can be expected to produce the creep damage accumulation processes accompanying extension, eg grain boundary creep cavitation, and, ultimately a tensile creep rupture. This has been confirmed for small punch testing by post-test optical and scanning electron microscopy. Impression creep however will not generate creep cavities and will not produce a specimen failure. This test method is intended to produce what may be termed an “intrinsic” creep deformation without damage accumulation. The creep strains produced can however be used to predict tensile creep behaviour.

3.3.2 MODELLING OF TEST PROCESS

Conventional small-scale creep testing can be modelled in the same way as full sized creep specimens. Some modelling of strain development and deformation for the small punch test has been carried out at a number of centres with interest in this test method, although more work is required in this area. Correlation of small punch with conventional testing is therefore currently made on an empirical basis. The impression creep test, in comparison, is fully supported by a well documented body of finite element studies and the mathematically modelling is regarded as robust.

3.3.3 EQUIVALENCE OF CONVENTIONAL TEST AND SMALL-SCALE TEST LOADS

Different laboratories/test houses have adopted or developed different versions of these techniques, the different detailed geometries employed making comparisons of results difficult. A primary goal of modelling work is to derive an equivalence for the loads applied in the various test geometries and interchangeability of results obtained by different laboratories/test houses using different variants of the same technique, or indeed between different techniques. Even for small punch testing, which is now used at a number of centres in Europe, information on load equivalence may not be freely available. There is evidence that this varies from one class of material to another and it is to be hoped that eventually sufficient information will become available to make small-scale to conventional correlations possible.

3.3.4 LIMITATIONS OF SIZE.

While specimen size is an obvious aspect of small-scale creep testing, it should be noted that some components of interest, eg hot gas path items in combined cycle gas stations and the associated parts of aerospace engines, operate in very thin section sizes. Small-scale test specimens may realistically reflect the actual size of interest in these cases.

Where small-scale testing is attempting to simulate thicker section behaviour, specimen size must be considered in the light of structurally significant microstructural dimensions. A large grain size may exceed the thickness of a small punch specimen, or the cross section size of the gauge section of a small-scale conventional specimen. In both cases however, the grain size is unlikely to exceed the corresponding longer dimension (diameter of the punch disc, axial length of the gauge length of the small-scale conventional specimen) for most materials. There will therefore be grain boundaries available to sustain deformation during the test. In the case of nickel based superalloys however, where exceptionally large grain size can be encountered, grain size may exceed even the larger specimen dimension. Impression creep specimens, for which in principle there is no restriction on thickness, will generally have sufficient grains in this direction. A large indenter will also sample numerous grains across the specimen.

Particular difficulties are presented by welds, where eg a weld bead dimension would typically exceed the specimen dimensions for small-scale conventional and small punch testing. For impression creep it may be possible to place an indenter within a zone of interest, eg HAZ or a defined part of an HAZ.

A further size effect, which is particularly important for small-scale conventional testing, and to some extent small punch, is the accuracy with which specimen alignment can be achieved. Misalignment giving rise to additional bending or torsion loads on specimens will be likely to increase experimental scatter.

3.3.5 SPECIMEN SURFACE EFFECTS

This is another aspect of specimen size limitation. Except for those cases where the specimen size and test conditions are representative of service conditions, oxidation/depletion effects during the test may significantly affect the mechanical properties of small specimens. This may be particularly true of longer term tests where testing in a controlled atmosphere may need to be considered.

Available evidence from small punch testing, however, is that there is not much difference in results when comparing tests in air to tests under argon. In the case of impression creep testing the material being loaded is protected from oxidation to an extent by the indenter,

and oxidation is considered less important.

3.3.6 COMPONENT SURFACE EFFECTS

Sampling will be limited in general to accessible free surfaces, eg the internal bores of hollow rotors, the external surfaces of steam lines or headers. In view of surface effects such as oxidation or carbon depletion, either during manufacture or in service, sampling may obtain material with properties unrepresentative of bulk material properties. Such effects, and their subsequent impact on measured properties, need to be investigated.

3.3.7 REPRODUCIBILITY

Because of sampling and testing costs, small-scale testing exercises on actual plant components have generally involved small numbers of specimens. These activities need to be backed up by more extensive repeat testing of material the availability of which is not a constraint. Because of the factors already discussed, it is likely that small-scale testing will exhibit more scatter than conventional creep tests. Typical variation in nominally identical tests needs to be investigated.

3.3.8 DEFINITION OF SPECIMEN ORIENTATION

Because of the wide variety of potential applications for small scale testing it may not be possible to define small specimen orientation with respect to the sampled component in a way which will be meaningful in all situations. It should be noted that, whereas in conventional uniaxial specimens material deforms in the direction of the loading axis, this is not the case for disc specimens.

It is important therefore that the orientation of the plane of the sampled disc is defined with respect to the component or microstructure from which the sample is taken. In the case of impression creep testing, where rectangular indenters can be used, further definition of testing orientation within the disc may be necessary.

3.4 THE PRACTICAL APPLICATION OF SMALL SCALE TESTING

3.4.1 WHERE AND HOW TO SAMPLE

Guidelines are required on the most appropriate locations to sample and the most reliable sampling techniques. The choice of location is essentially the same decision which must be made for all remnant life testing, ie which location most effectively represents the creep life usage most relevant to the assessment being carried out. The most effective sampling techniques will be more a matter of practical experience.

3.4.2 ACCESS/EXTRACTION FOR SAMPLING

Limitations to access for sampling devices need to be considered. For particularly inaccessible locations these considerations need to be extended to cover the capture and removal of the detached sample, the extraction of the sampler, and, in the worst cases, recovery of the situation if sampling fails. Alternatives to mechanical sample extraction include electro-discharge and water jet cutting.

3.4.3 AVAILABILITY/COSTS OF TESTING SERVICES

Most cases of the application of small-scale testing will involve specific plant components which require assessment, rather than more generic materials evaluations for which larger

amounts of material are likely to be available. In these circumstances the timescale for testing will often be critical and the availability of a choice of acceptable testing facilities and testing costs will determine the longer term viability of such techniques. A choice of test houses in Europe, important both for competitive costs and availability of machines at short notice may therefore become critical.

3.4.4 AVAILABILITY/COSTS OF SAMPLING SERVICES

A further critical item may be the availability of a choice of providers of sampling services. Constraints in this area may well limit the application of these techniques, even in the presence of a sufficient number of test house options. Reduction in the costs of in-situ sampling is also a priority.

3.4.5 USE OF THE RESULTS

A consensus among end users is called for in relation to the interpretation and application of the results obtained. Ideally guidelines should be developed on all aspects of sampling and testing and assessment.

3.4.6 ACCEPTANCE OF RESULTS BY THIRD PARTIES

An important aspect of the way results are to be used in practice is their acceptability to third parties, eg insurers, boiler inspectors, regulatory bodies, etc. The most appropriate way of ensuring this would be the involvement of such organisations in the development of guidelines.

3.5 EXAMPLES OF APPLICATION TO PLANT

3.5.1 SMALL SCALE CONVENTIONAL TESTING – P22 INTERCONNECTOR PIPE

A refinery furnace interconnection pipe, inspected during a normal residual life extension routine was found cracked close to, but not at, a circumferential weld to a flange. The pipe, made of ASTM A335 grade P22 (2,25 Cr 1 Mo) steel, ca. 350mm in diameter with 18mm wall thickness, was identified as having been in service on the same plant for more than 20 years at 535°C and 60-80 bar, conducting semi liquid petroleum derivatives. Before repair was undertaken, a check on the actual creep strength was required. Due to the particularly bad accessibility of the pipe on its rear side, which did not allow non destructive inspection or weld repair on the whole circumference, a test program of short and medium duration creep tests was carried out on:

- two 50mm x ca. 50mm x 3mm thick samples cut from the redundant thickness of the pipe, which due to corrosion allowance was quite large, in two different positions by low invasive sampling in the piping segment which had experienced the highest operating temperature,
- one 500mm full length pipe sample cut from the pipe in a lower temperature area with better accessibility for repair.

From the 3mm thick samples, avoiding the surface near decarburised area and the zone affected by cutting side effects, 4 and 5 micro specimens of gauge diameter 1.2 to 1.35mm x 25mm in length respectively were machined. Specimens with heads for gripping could be produced directly from the available testing material. Tests were then conducted in parallel under full vacuum (pressure less than 10^{-4} torr) and in high purity Argon. Supplemental getter material oxidation protection shields around the gauge length were also applied. For

comparison, 10 creep specimens of standard UNI 5111 size were also machined and tested in air. Tests were conducted at temperatures between 550 and 625°C at stresses less than twice the service stress which lasted between 500 and 11.000h (microspecimens in Argon), 100 and 5.000h (microspecimens in vacuum), 500 and 20.000h (standard specimens in air).

The results of all specimens, including the ECCC base line for a 10CrMo9.10 material, are summarised in a Larson-Miller plot in Figure 1. Vacuum and argon microspecimen tests were in excellent agreement with the standard specimen creep results in air. For shorter durations (low Larson Miller parameter) the rupture strength is clearly smaller than for virgin material, but for higher Larson-Miller parameters, virgin material strength was achieved by the post exposure material. Figure 2 shows an example of comparable strain vs. time curves as measured on these tests.

Residual life at service temperature and stress higher than 100.000 h could be determined from the Larson-Miller curve shown in Figure 1. In addition microstructure assessment on sample and creep specimen material confirmed the adequate creep strength of the post exposure material, which exhibited only limited bainite deterioration.

The pipe was therefore repaired and has been in service, without any known further problems, for ca. 65.000h (35.000h of which were at only 45 bar).

By comparing the results shown in Figures 1 and 2, it was considered that micro-specimen creep testing in argon, which is less expensive than in vacuum, could be an useful technique for further serviceability evaluation for components which cannot be easily replaced.

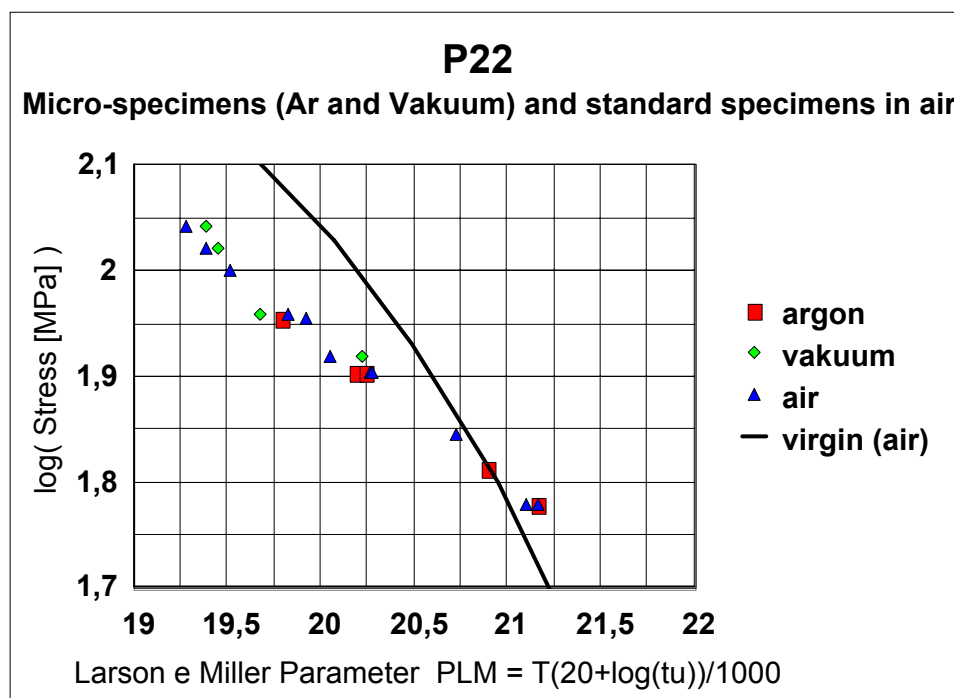

Figure 1: Rupture times of microspecimen tests in argon and vacuum compared to standard specimen tests in air (same material) and ECCC creep strength for virgin 10CrMo9.10 material.

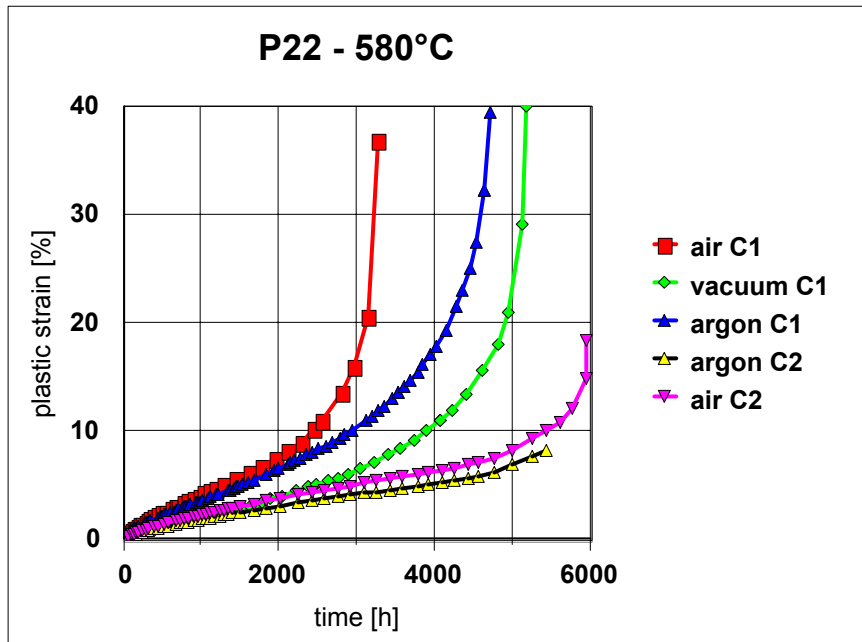

Figure 2: Creep strain vs. time curves for standard specimens in air and micro-specimens in vacuum and argon at 80 MPa (C2) and 83 MPa (C1).

3.5.2 SMALL PUNCH AND IMPRESSION CREEP TESTING - MODIFIED 9CR (GRADE 91) HEADERS

Following the premature failure of a retrofit modified 9Cr header endplate, a need arose to establish whether similar failures could occur at other power stations. Investigation of the endplate failure, several damaged endplates found by inspection, and a number of premature transition bottle failures, revealed several common features. All the problem forgings, which had been supplied to ASME requirements, showed nitrogen levels in the lower part of the specified range, aluminium levels in the upper part of the specific range, and low hardness.

A survey of data supplied by the manufacturers was carried out for other modified 9Cr forgings supplied for retrofit headers. The compositional results, expressed as Log(N/Al), and hardness values are compared with the problem forgings in Figure 3.

Using the results shown in Figure 3, eight further forgings with values of Log(N/Al) and hardness close to those of the problem forgings were selected for small scale sampling. This was carried out by a combination of crude sampling (with a hacksaw), where component geometry and access permitted, and miniature scoop sampling. One further forging of interest was available as material surplus to one of the header manufacturing contracts.

A small punch test programme and an impression creep test programme were then carried out on the nine forgings, along with samples of the failed endplate and the header shell adjacent to it. It should be noted that no significant creep damage was found on the shell side of the endplate failure and it was assumed that the shell represented "normal material".

For the small punch tests a single test machine was used, with each test being restricted to 500hrs duration at 191N load and 600°C. For the endplate this was sufficiently long for the specimen to fail. All other tests were halted short of failure. The minimum deformation rates recorded during the test are shown in Figure 4. It can be seen that the rates and, by

implication the creep strengths, of the forgings are similar to each other and to the shell adjacent to the endplate failure. The endplate specimen itself in contrast shows a much higher deformation rate, about three times higher than the worst sampled forging.

The impression creep tests were also limited to a single test machine and test durations less than 500hrs. The minimum creep rates recorded during the test are shown in Figure 5. Again it can be seen that the creep rates and, by implication the creep strengths, of the sampled forgings are similar to each other and significantly lower than that of the endplate.

These results were used to justify a scaling down of the inspection programme initiated for other retrofit modified 9Cr headers immediately after the endplate failure.

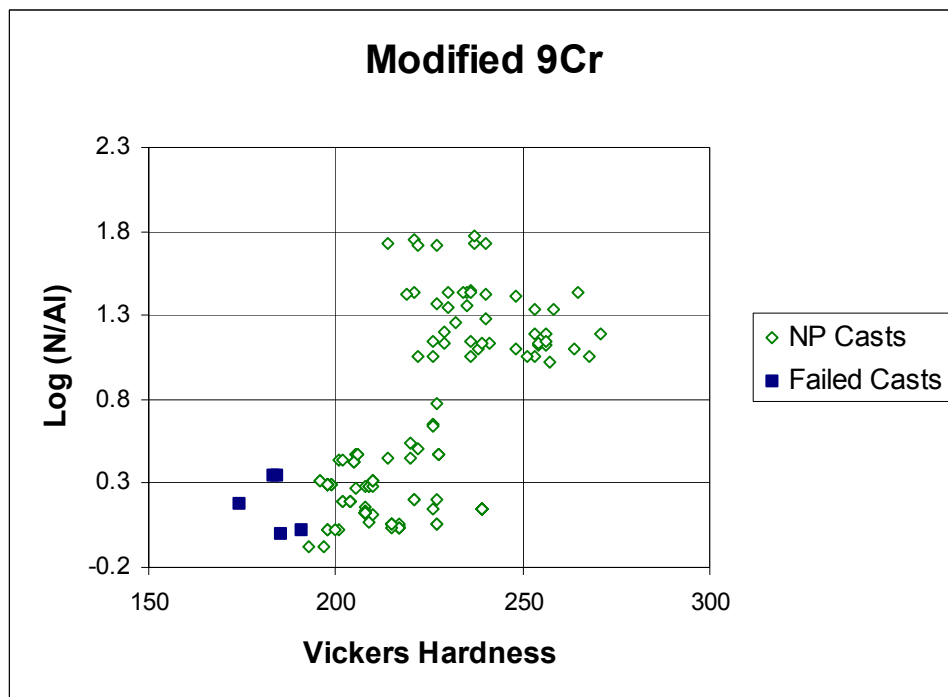

Fig.3. Comparison of investigated Mod9Cr forgings (NP) with recorded failures.

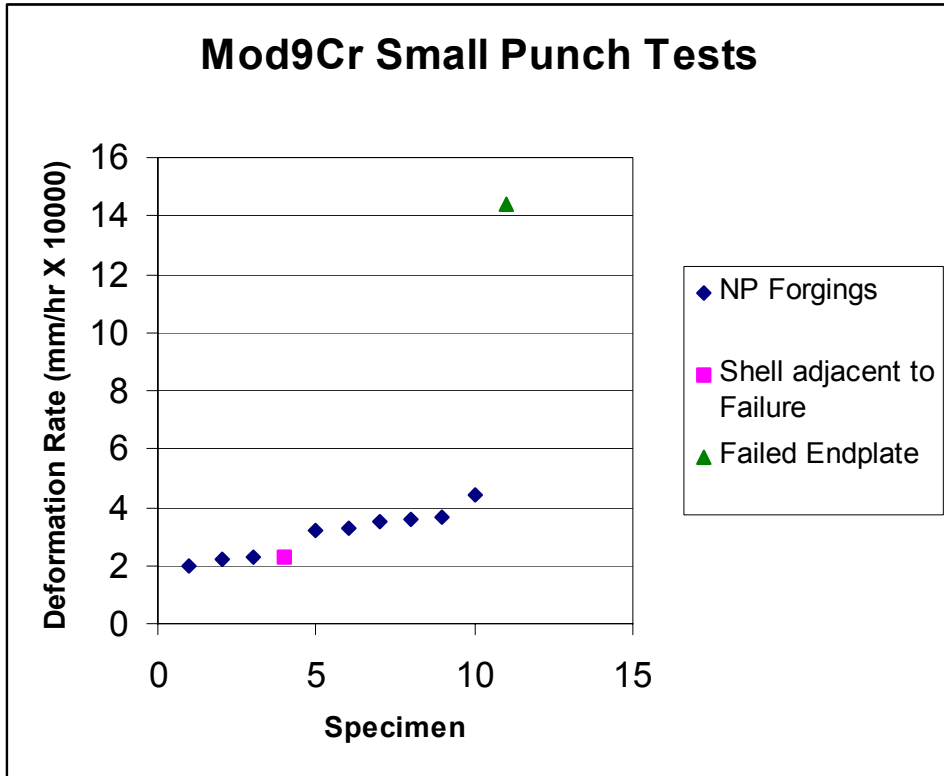

Fig.4. Comparison of small punch deformation rates for investigated forgings (NP), the failed endplate, and unfailed shell (191N / 600°C).

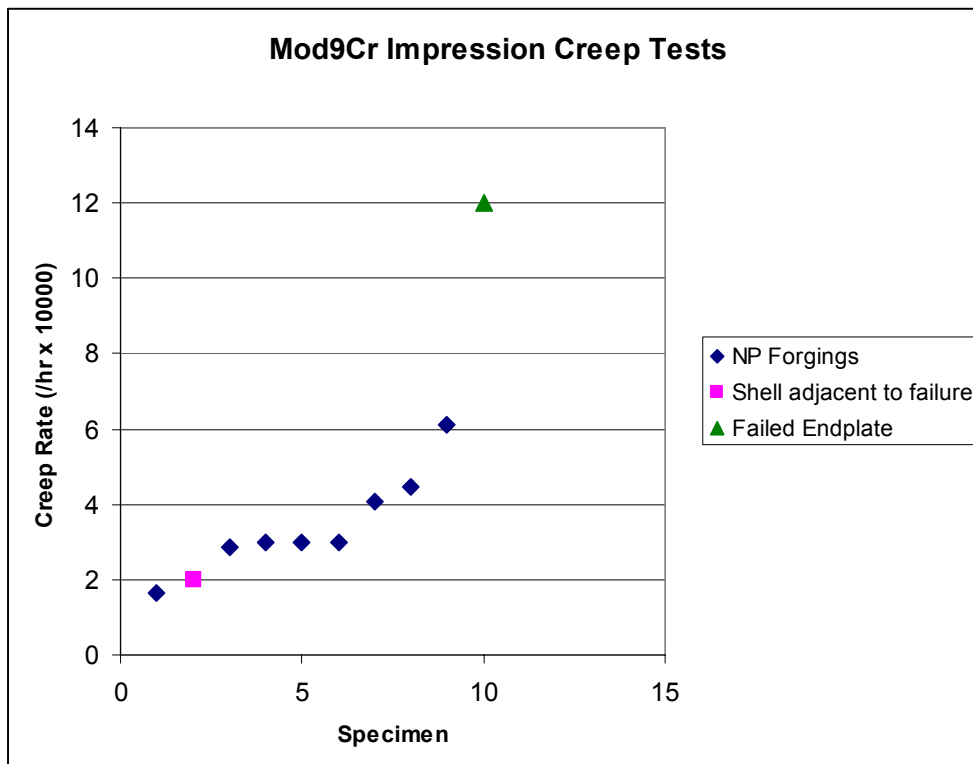

Fig.5. Comparison of impression creep rates for investigated forgings (NP), the failed endplate, and unfailed shell (155MPa/600°C).

3.6 CONCLUSIONS

Each of the three testing methods considered here can be used to provide a qualitative comparison of creep strength. The tests should be equally effective in, for example, ranking a range of casts in order of their creep strength. In particular the identification of abnormally weak or strong materials should be straightforward.

Where quantitative data, equivalent to those produced by conventional full scale tests are required, the optimum test method depends on which aspects of creep are of greatest relevance.

If both creep strain rate and failure behaviour are of interest the small scale conventional test may be the most appropriate. This has the same testing geometry and the material is deformed in the same manner with equivalent creep damage accumulation.

Where creep strain rate is the major concern the impression creep test may provide the best option. Although this test method produces deformation without the associated creep damage, the test geometry is well defined by finite element modelling and does appear to provide creep strain rates equivalent to those in full scale conventional tests for a wide range of materials. This test geometry is also particularly useful for measuring creep rates in the different parts of a weldment, ie weld metal, HAZ and parent, where these are present to a sufficient extent in the specimen. In the case of the HAZ this can only be achieved by the other test methods indirectly by simulated heat treatment. A further advantage of this form of testing is that the applied load can be systematically varied during the test to obtain creep strain rates at several values of stress in the same specimen. This can be used to derive values of the creep exponent .

blank page

APPENDIX 1

ECCC-WG1-PEDS POST EXPOSED (EX-SERVICE) MATERIAL TEST DATA SURVEY

E Gariboldi [Politecnico di Milano]

blank page

Appendix 1

ECCC-WG1-PEDS

Post exposed (ex-service) material test data survey

Contents

Overview.....	3a
Generation of post exposed test data.....	4a
Testpiece type and dimensions	6a
Particular environment, requirements, adopted standards	8a
Alloy classes used to generate PE material test data	10a
Minimum material pedigree for post exposure material data useful for assessment.....	12a

blank page

Overview

In 1998 a Questionnaire was circulated to European organisations involved in the generation and use of PE material creep data. The aim of the Questionnaire was to review creep testing methods for PE materials to form the basis of guidelines for the generation of PE material creep test data. 18 organisations out of 54 responded to ECCC-WG1-PEDS. The following tables schematically summarize the results of the survey. Each table collects the answers to a series of questions (the question number is given in the first row) on a general subject (eg. testpieces, alloy classes, etc.).

GENERATION OF POST EXPOSED TEST DATA

Question			1	2			3		
Ref. No.	General information		Generation of PE test data	Creep rupture tests on PE material			Test material extracted as		
	organization type	organization activity		without strain measurement	with strain measurement	no	bulk-sections	boat-shaped samples	plug samples
1	Plant Manufacturer	Power Generation	regular	X	X	-	X	-	X
2			regular	X	X	-	X	-	-
3	Plant Manufacturer	Power Generation	regular	X	X	-	X	X	X
4	Plant Manufacturer Institute/Cons.	Power Generation	infrequent	X	X	-	X	X	X
5	Inspection Company Notified body	Power Generation Petro-chem/Trans.	no	-	-	X	-	-	-
6	Institute/ Consultant	Power Generation	regular	X	X	-	X	-	-
7	Institute	Techn. Consultancy Research	regular	X	X	-	X	X	X
8	End User	Power Generation	no	-	-	X	-	-	-
9	End User	Power Generation	infrequent	X	X	-	X	(a)	X
10	Institute\Consultant	Power Generation	regular	X	X	-	X	-	-
11	Institute\Consultant	Power Generation	infrequent	-	X	-	X	-	-
12	Plant Manufacturer	Power Generation	infrequent	X	-	-	X	-	-
13	Plant Manufacturer	Power Generation	infrequent	-	X	-	X	-	X

Question			1	2			3		
Ref. No.	General information		Generation of PE test data	Creep rupture tests on PE material			Test material extracted as		
	organization type	organization activity		without strain measurement	with strain measurement	no	bulk-sections	boat-shaped samples	plug samples
14	End User	Power Generation	regular	X	X	-	X	X	-
15	University	//	infrequent	-	X	-	X	-	-
16	Institute/ Consultant	Power Generation Petro-chemical	regular	X	X	-	X	X	-
17	Plant Manufacturer	Power Generation	infrequent	X	-	-	X	-	X (rare)
18	Plant Manufacturer/ End User	Power Generation	regular	X	X	-	X	-	-

Notes:

(a) discs using a SSAM sampler

TESTPIECE TYPE AND DIMENSIONS

Question	4/5			4/5			4/5			4/5			4/5			4/5			4			
Ref. No	Full-size uniaxial / homogeneous			full-size uniaxial / weld extended			sub-size uniaxial / homogeneous			subsize uniaxial / weld extended			mini uniaxial / homogeneous			mini uniaxial / weld extended			mini disc			other testpiece
	d ₀ (mm)	±Δd ₀ (mm)	L _r (mm)	d ₀ (mm)	±Δd ₀ (mm)	L _r (mm)	d ₀ (mm)	±Δd ₀ (mm)	L _r (mm)	d ₀ (mm)	±Δd ₀ (mm)	L _r (mm)	d ₀ (mm)	±Δd ₀ (mm)	L _r (mm)	d ₀ (mm)	±Δd ₀ (mm)	L _r (mm)	a ₀ (mm)	±Δa ₀ (mm)	D (mm)	Details
1	≥5	0.02	≥3d ₀	-	-	-	≤4	0.02	≥4d ₀	-	-	-	-	-	-	-	-	-	-	-	-	-
2	≥5	0.02	≥3d ₀	X	X	X	X	X	X	X	X	X	-	-	-	-	-	-	-	-	-	(a) see below
3	≥5	0.02	-	-	-	-	X	X	X	-	-	-	4&5	0.01	12	X	X	X	-	-	-	(b) see below
4	≥5	0.02	≥3d ₀	≥5	0.02	≥3d ₀	3-5	0.01	≥12	3--5	0.01	≥12	2--3	0.005	≥12	2--3	0.005	≥12	-	-	-	-
5	-	-	-	-	-	-	-	-	-	-	-	-	-	-	-	-	-	-	-	-	-	-
6	≥5	0.02	≥3d ₀	-	-	-	-	-	-	-	-	-	-	-	-	-	-	-	-	-	-	-
7	≥5	0.02	≥3d ₀	-	-	-	3	-	20	3	-	20	-	-	-	≥1	-	≥15	-	-	-	-
8	-	-	-	-	-	-	-	-	-	-	-	-	-	-	-	-	-	-	-	-	-	-
9	≥5	0.02	≥3d ₀	-	-	-	3.8-4.5	0.013 (d ₀ =4.5mm)	5 do	-	-	-	-	-	-	-	-	-	0.5	0.001	10	(c) see below
10	-	-	-	-	-	-	-	-	-	-	-	-	-	-	-	-	-	-	-	-	-	-
11	≥5	0.02	≥3d ₀	-	-	-	-	-	-	-	-	-	2.5	-	5do	-	-	-	-	-	-	-
12	9	0.02	6 do	-	-	-	-	-	-	-	-	-	2	0.02	5do	-	-	-	-	-	-	-
13	≥5	0.02	≥3d ₀	-	-	-	-	-	-	-	-	-	-	-	-	-	-	-	-	-	-	-
14	≥5	0.02	≥3d ₀	X	X	X	X	X	X	-	-	-	-	-	-	-	-	-	-	-	-	-
15	≥5	0.02	≥3d ₀	-	-	-	-	-	-	-	-	-	-	-	-	-	-	-	-	-	-	-
16	≥5	0.02	≥3d ₀ (d)	≥5	0.013	≥3d ₀ (d)	≥3	0.013	≥3d ₀ (d)	≥3	0.013	≥3d ₀ (d)	<3	0.013	≥3d ₀ (d)	<3	0.013	≥3d ₀ (d)	-	-	-	-

Question	4/5			4/5			4/5			4/5			4/5			4/5			4			
Ref. No	Full-size uniaxial / homogeneous			full-size uniaxial / weld extended			sub-size uniaxial / homogeneous			subsize uniaxial / weld extended			mini uniaxial / homogeneous			mini uniaxial / weld extended			mini disc			other testpiece
	d _o (mm)	±Δd _o (mm)	L _r (mm)	d _o (mm)	±Δd _o (mm)	L _r (mm)	d _o (mm)	±Δd _o (mm)	L _r (mm)	d _o (mm)	±Δd _o (mm)	L _r (mm)	d _o (mm)	±Δd _o (mm)	L _r (mm)	d _o (mm)	±Δd _o (mm)	L _r (mm)	a _o (mm)	±Δa _o (mm)	D (mm)	Details
17	≥5	0.02	≥3d _o	-	-	-	-	-	-	-	-	-	-	-	-	-	-	-	-	-	-	-
18	≥5	0.02	≥3d _o	≥5	0.02	≥3d _o	-	-	-	-	-	-	≥2	0.01	≥3d _o	≥2	0.01	≥3d _o	-	-	-	-

Notes:

- (a) Full size component tests. Full size T joints, max length 1500mm; width 1200mm; p_{max} 500bar; T_{max} 1000°C. Also tests on full size bends
- (b) All full size specimens are proportional. The lack of a definition of a fixed d_o, T_o, L(L_r) ratio is a problem with existing ECCC guidelines. Ductility is of increasing importance and either a proportional specimen or a ductility conversion for differing specimen L_r/D_o is required
- (c) Indentation creep: utilises same disc sampling technique but the test specimen is typically 10mm x 15mm x 2mm (the test itself is indentation at high temperature)
- (d) Preferably gauge length proportional size = 5.65*(gauge area)^{0.5}

Legend:

- : specimen type not used
X : dimensions not defined

PARTICULAR ENVIRONMENT, REQUIREMENTS, ADOPTED STANDARDS

Question	6		7	8
Ref. No.	Particular environment	Special techniques	Testing standards followed	Standard requirements not met
1	-	-	French and ASTM Standards	The use of strip specimens (not round specimens)
2	Not for ordinary tests, sometimes for tubes special equipment	3h: deformation measurements with creep pipes + 'spica'. T > than service temperature, same internal pressure.	ISO	Stresses of component test are not well defined. They can only be calculated because they are multiaxial
3	Very rarely Ar atmosphere for high temperature small diameter specimens	-	ISO 204, BS 3500 ECCC guidelines	Proportional ratio or gauge length to gauge diameter ratio
4	no	-	pr EN 10 291 ISO 204	$L_r \geq 5 (\pi d_o^2/4)^{0.5}$ $d_o=3\text{mm}$ (only ISO 204)
5	-	-	-	-
6	Ar atmosphere for isostress testing	-	BS ECCC guidelines	None (when standards cannot be met the test is not performed)
7	Sometimes (mini-specimen): Ar atmosphere or vacuum (not too low)	min. bending ($\Delta\epsilon$ at gripping $\leq 100\mu\epsilon$).	UNI 5111 ASTM E139	Size of specimens
8	-	-	-	-
9	Some full size and sub size tests carried out in Ar	-	BS where applicable (a)	Size of specimens
10	Air	-	DIN 50 118 (EN) when will be valid	None
11	-	Nickel coating for mini-uniaxial spec.	ISO	-
12	High purity Ar for mini-uniaxial testpieces, otherwise air	-	BS 3500 whenever applicable	-
13	-	-	DIN 50118	-
14	Ar atmosphere (Air atmosphere for less oxidation prone materials)	-	BS 3500	-
15	-	-	BS 3500	-

Question	6		7	8
Ref. No.	Particular environment	Special techniques	Testing standards followed	Standard requirements not met
16	Air, argon or vacuum; in pressure tests steam is the pressing medium	-	BS3500 parts 1, 3	None
17	Air	-	ASTM E139, E 292 ECCC guidelines	-
18	Argon or high vacuum	-	ASTM E139-83 (reapproved 1990)	-

Notes:

(a) In fact, most situations are related to specific components and often specimen size requirement cannot be met

ALLOY CLASSES USED TO GENERATE PE MATERIAL TEST DATA

Question	9			9			9			9			9		
Ref. No.	Low alloy ferritic steels			High alloy ferritic steels			Austenitic steels			Ni base alloys			Other materials		
	T (°C)	Tests No	Testing hours	T (°C)	Tests No	Testing hours	T (°C)	Tests No	Testing hours	T (°C)	Tests No	Testing hours	T (°C)	Tests No	Testing hours
1	≤ 750	6	≥ 3000	≤ 750	6	≥ 3000	≤ 800	6	≥ 3000	-	-	-	-	-	-
2	-	>30	-	600-700	<10	-	600-900	>10	-	850-1150	>10	-	-	-	-
3	<600	40	<10000	<700	30	<10000	-	-	-	-	-	-	-	-	-
4	RT to 700	-	-	RT to 1300	-	-	RT to 1100	-	-	RT to 1200	-	-	-	-	-
5	-	-	-	-	-	-	-	-	-	-	-	-	-	-	-
6	500, 520, 550, 570 600 (a)	125	417000	-	-	-	-	-	-	-	-	-	-	-	-
7	480-600	100	250000	-	-	-	500-800	30	20000	-	-	-	-	-	-
8	-	-	-	-	-	-	-	-	-	-	-	-	-	-	-
9	600-640	100	≤13000	600	10	<500 (discs only)	-	-	-	-	-	-	-	-	-
10	500-580	200	1000000	530-680	100	200000	-	-	-	-	-	-	-	-	-
11	625-710 560-635	14 20	9000 15000	-	-	-	-	-	-	-	-	-	-	-	-
12	570-630 (b) 550 (c)	24 6	42000 8000	-	-	-	-	-	-	-	-	-	-	-	-
13	530 500 550	-	47000 >100000 >100000	530 560	-	25000 15000	-	-	-	-	-	-	-	-	-
14	630-680 (d) X (f)	74 X	350000 X	X	X	X	-	-	-	-	-	-	-	-	-
15	<400	3	6300	-	-	-	-	-	-	-	-	-	-	-	-
16	600-700	500	300000	650-700	200	100000	700-900	200	100000	700-1100	100	50000	-	X	-

Question	9			9			9			9			9		
Ref. No.	Low alloy ferritic steels			High alloy ferritic steels			Austenitic steels			Ni base alloys			Other materials		
	T (°C)	Tests No	Testing hours	T (°C)	Tests No	Testing hours	T (°C)	Tests No	Testing hours	T (°C)	Tests No	Testing hours	T (°C)	Tests No	Testing hours
17	510-650	>100	50 to 10000	-	-	-	-	-	-	-	-	-	-	-	-
18	600-700	15-20	10-2000	-	-	-	600-750	2-4	10-2000	-	-	-	-	-	-

Notes:

- (a) 2¼Cr1Mo steel
- (b) 1CrMoV rotor steel
- (c) 0.5Mo rotor steel
- (d) ½Cr½Mo¼V steel
- (e) Weldments CrMoV to CrMoV and P91

Legend:

- X : details not specified
- : no indicated PE tests

MINIMUM MATERIAL PEDIGREE FOR POST EXPOSURE MATERIAL DATA USEFUL FOR ASSESSMENT

Question	10			
Ref. No.	Material	Operating conditions	Sampling	Other
1	-	-	-	-
2	-	Operating hours Design stress (or operating pressure) and temperature	-	Heat <i>flux</i>
3	Type of weld metal	Temperature, time, estimated stress, stress direction	Location	-
4	Material type (approximate chemical composition), Heat treatment or original structure (e.g. bainite). Rupture strength table of material type	-	Samples from same or identical service components	Future loading (temperature and stress) of the component
5	-	-	-	-
6	Material class, nominal composition	Service condition (T, σ)	Exact sampling position	-
7	Grade, chemical composition Component type Manufacturing details (welds, man. Method (pipe..))	Nominal and real service conditions (T, $\sigma(p)$) Service duration	Sampling method and position,	Detected creep damages (NDT) Investigation campaign motivation (failure, inspection, mapping..)
8	-	-	-	-
9	-	-	Position and orientation where the material is sampled from	-
10	-	Stress, service time and temperature	-	-
11	-	-	-	-
12	Chemical composition Microstructure Strength (hardness)	Operating temperature, stress, time	-	-
13	Chemical composition Heat treatment Mechanical properties	-	-	-
14	Material grade confirmed by Metascop or better	Average operating temperature, estimated or operating stress, operating hours	-	-

Question	10			
Ref. No.	Material	Operating conditions	Sampling	Other
15	Chemical analysis	Temperature, stress (average or reduced to average in different operating periods), time (total or for each operating period).	PE material for a series of test should have operated under the same conditions	-
16	Material specifications and mill certificates	-	-	-
17	Usually without pedigree	Usually without pedigree in no exposed position	usually without pedigree	-
18	-	Service time - T, σ (nominal) N° start up/shut down of the component Work condition for every period	Minimum 5-6 specimens	-

APPENDIX 2

CREEP TESTING ON PE MATERIALS: LITERATURE SURVEY

E Gariboldi [Politecnico di Milano]

blank page

Appendix 2

ECCC-WG1-PEDS

Creep testing of PE materials: literature survey

Contents

Overview		2b	
1.	Introduction: creep testing on PE materials	3b	
2.	Sampling of PE material	3b	
	2.1 Description of some sampling techniques	5b	
	2.1.1 Destructive sampling	5b	
	2.1.2 Boat sampling and jig drilling		5b
	2.1.3 Plug sampling		5b
	2.1.4 Axial ring sampling	5b	
	2.1.5 Other sampling techniques	6b	
3.	Specimens for creep testing PE materials	6b	
	3.1 Homogeneous sub-size and miniature specimens	7b	
	3.2 Weld-extended sub-size and miniature specimens	8b	
	3.3 Mini-discs creep test (small or shear punch creep tests)	8b	
4.	Creep testing equipment for sub-size and miniature specimens	9b	
	4.1 Creep testing machine	9b	
	4.2 Alignment of the specimen	9b	
	4.3 Gripping equipment	10b	
	4.4 Strain measurement system	10b	
5.	Environmental effects on the results of creep tests	10b	
	5.1 Oxidation effects on creep curves	11b	
	5.2 Laboratory practices to reduce environmental effects	13b	
6.	Creep testing practices for PE materials	14b	
7.	Conclusions	14b	
8.	References	14b	
9.	Figures	16b	

Overview

The following review describes the techniques for sampling and creep testing Post-Exposure (PE) materials presented in literature. Since creep testing data on these materials are of great importance in life assessment of components, particular attention and care have to be paid not only to the execution of the test itself, but also to the sampling methods and to some characteristics of the creep specimen. For this reason, several features of creep testing practice have been taken into consideration in the review: material sampling methods and sample size, creep specimen geometry and specimen preparation, creep testing equipment and procedure, testing environment. All these elements could, in fact, affect the creep data.

1. Introduction: creep testing of PE materials

In the first period of activity ECCC dealt with virgin materials to be used for components operating in the creep regime¹. The need to consider also materials previously exposed to creep temperatures during service (often referred as Post-Exposed or ex-service materials) was also expressed, above all by Utilities. The creep data on PE materials are in fact considered of fundamental importance (even if often associated with other investigations such as dimensional and optical controls, NDT, metallographic analyses, etc.) in the procedures for assessing residual life of operating components or plants, or for monitoring their current safety status^{2,3}. As a matter of fact, the knowledge of the creep characteristics of virgin material (when, rarely, available for the same batch of material) is often insufficient for life assessment of components or plants due to experimental scatter and to the need of extrapolation techniques to long duration. Further, it should be considered that real operation conditions of the PE material during service could have been different from the design ones and/or could have been varied during service, thus leading to a mechanical behaviour of serviced part different from that foreseen on the basis of tests on virgin material and/or difficult to be foreseen.

On these bases, a subgroup of WG1, Post Exposure Test Data (PEDS) was constituted. One of the aims of the subgroup was the definition of criteria for acceptability of existing PE material creep and stress rupture data and the generation of new ones^{1,4}. For this reason, a survey on literature dealing on the experimental practices for sampling and creep testing PE materials as well as a the techniques presented has been performed. They will be presented hereafter.

As previously stated, the main goal for testing PE material is to obtain information in order to carry out life assessment either of the component from which material was extracted or of other (often referred as ‘comparable’) components. Thus there is (particularly in the first case) the need to extract from the component a very limited portion of material. The material removal should leave at minimum levels the alterations of the component geometry, microstructure, mechanical characteristics. For this reason, particular attention and care have to be paid to the sampling methods. As a consequence, a very limited amount of PE material is available obtaining specimens for creep tests. Specimens of small size and having particular geometry are prepared for creep testing. Modified or special testing equipment is often used as well. Further, some effects such as environmental or loading effects that are reasonably negligible on specimens of usual size, can heavily affect tests results when specimen of very limited size are considered. These effects have been often, even if differently, considered by laboratories where tests on PE materials were carried out. Special equipment and environments as well as testing procedures, are sometimes reported in literature.

The abovementioned features, typical of PE materials (such as sampling methods and sample size) or of creep testing of specimen of reduced size (such as testing equipment or environmental effects) will be hereafter presented separately.

2. Sampling of PE material

There are two conceptually different ways to obtain PE material from serviced parts in order to perform creep testing. The first one is to sample destructively the material out from a component which will not be serviced any more. In this case the most representative zones as far as operating conditions (stress and temperature) are concerned can be freely chosen. Further, the amount of PE

material can often be sufficient for machining a suitable number of standard-size specimens. Results obtained with such experimental investigations will then be used for the assessment of other ‘comparable’ components.

The second approach consists in a ‘non destructive’, or better ‘semi-destructive’, sampling of material from an exposed component which will then be returned to service. Since the sampled material comes from components which will still be serviced, the results of the creep testing campaign can then be directly used to the assessment of the same component. It is evident that the term ‘non destructive’ is a slightly improper term for this approach. In fact, a certain amount of material is always cut out from the component. The amount of sampled material, the component and the location from which it is taken, as well as the need for repairing the part after sampling determine the degree of ‘non destructivity’ of the material sampling. The sampling technique can reasonably be considered as ‘non destructive’ only when the component does not need to be repaired. Hereafter this latter definition will be followed.

There are a series of points that support the interest for non destructive sampling⁵⁻⁹:

- plant operators are reluctant to allow the removal of large amounts of material and to perform weld repair on components: this can in fact imply long shut down of the plant, and related costs, to be added to those of repair;
- repairing can be deleterious for the component itself and the repaired component characteristics and behaviour do not correspond any more to those of the investigated PE material. Further, repair can not even be taken into consideration for some components;
- the need to remove a limited amount of material may be dictated by the presence of a very limited volumes subjected to a particular (or a characteristic) set of operating conditions. This can be due to the complex component shape or can be evaluated via damage inspections etc⁵;
- in some cases the small component size (i.e. thin tubes) or the location of the volume of material to be removed allows only the extraction of small samples.

On the contrary, requirements exist on the minimum amount of material to be removed. This latter depends on the experimental investigations to be performed on it. If some chips from a component are enough for the determination of its chemical composition, a greater material volume, not deformed nor heated by the extraction operations, is needed for microstructural examinations. The amount of material for a creep campaign on a PE material is of course much greater. It depends on the number and size of creep specimens to be obtained as well as on the location and orientation within the component. Since a minimum number of specimens is always needed for a creep testing campaign (depending on the assessment procedure to be used for RLA) the specimen size is often reported as the critical factor. In the following review the specimens will be divided into three groups depending on their size. Specimens matching the requirements stated by ECCC in [1]^{*} are considered full-size specimens. Reduced-size specimens are classified into two groups: sub-size specimens (for which $3 \text{ mm} \leq d_0 \leq 5 \text{ mm}$) and miniature specimens (for which $d_0 < 3 \text{ mm}$). This distinction, based on specimen size, roughly corresponds to the possibility for destructively or non destructively sampling PE materials from service components. In fact, the conventional dimensions of full-size specimen dimensions can not be obtained by means of such a ‘non destructive’ techniques, for which ‘sub-size and miniature specimens are needed. Further, as for the case of microstructural investigations, the alteration of the material should be as limited as possible during extraction from the serviced component.

* Among other, the fundamental requirements for full-size specimens are $d_0 \geq 5 \text{ mm}$ (where d_0 is the diameter of the gauge length) and a reference length L_r greater than 3 times d_0 (for definition of L_r is given in ref.1)

From the above points the existence of a relation between specimen size, sampling method and material location/component type is clear. Hereafter, some semi-destructive or non-destructive sampling methods will be presented, considering both their geometric characteristics and application field.

2.1. Description of some sampling methods

2.1.1. Destructive sampling

Destructive sampling usually involves the material removal by means of bulk sections. Since the components have been removed from service, there are generally less problems of accessibility of the sampling regions. The amount of PE material is often enough to machine full-size specimens of standard size. Destructive sampling is a common method to obtain creep data for PE material and is adopted by many Laboratories, often in combination with 'non destructive' techniques.

2.1.2. Boat sampling and jig drilling

A typical semi-destructive sampling method is boat sampling. The material is removed by means of the boat saw, or trepanning saw, where a slightly concave circular saw blade is plunge fed into the material. Cutting in two adjacent locations using the suitable orientation of the concave circular saw results in the removal of a volume of material having the typical boat hull⁶ shape with length ranging from 25 to about 100 mm. Advantages of this sampling method are the use of a portable equipment that enables to extract the material directly on the plant. The main disadvantages mentioned in literature are the need of sufficient accessible surfaces as well as the need of repairing the component after material removal due to the size and shape of the sampled material.

Small samples of PE material can be removed also by jig drilling. Using this technique two opposite series of holes of small diameter (for example 3 mm (Ref.7)) and inclined with respect to the surface (for example 45° (Ref. 7)) are drilled so that holes meet at the bottom of the sample, as clearly illustrated in Figure 1⁷. Other geometries of the removed samples can be obtained by trepanning methods⁷.

2.1.3. Plug sampling

A limited amount of material can be obtained in a semi-destructive way also by trepanning the component surface so as to obtain a cylindrical sample (often referred as a plug sample). After material removal, the component needs weld repair before being returned to service duty¹.

2.1.4. Axial ring sampling

A characteristic material removal can be obtained from turbine bores in the form of axial rings. The rotor bore has to be overbored for tool clearance, the ring has to be machined and then to be split for its removal. The ring dimensions are typically⁶ 38 mm height (axial dimension), 25 mm thickness, the internal diameter being that of the bore. After the time-consuming operation of material removal, the rotor could be re-serviced without repairing, even if in this case it would be subjected to increased stress field in the removal area⁶

2.1.5. Other sampling techniques

Other sampling non-destructive techniques have been proposed in the last decade. The aim is to reduce the amount and depth of removed material while leaving unaltered material microstructure and mechanical behaviour after sampling as well as avoiding weld repair and stress concentrations^{2,5,6}. The wall thickness of high-temperature parts (for example pipes or pressure vessels) is usually well above the minimum size imposed by design. Thus the removal of shallow-shaped samples leaving at least the minimum wall thickness and not requiring repair is - at least in principle - possible. It requires the development and assessment of new creep specimens and testing techniques.

Hereafter two of these sampling techniques described in literature are presented.

The first sampling method uses as a cutting tool a saw characterised by a hemispherical shell cutter revolving around its axis of symmetry (Figure 2^{3,6}). The saw is rotated around a pivot axis parallel to the material surface so that a lens-shaped material sample can be removed. The size and geometry of the sample depend on the shell size and on the inclination of the axis of symmetry at the beginning of the cut. Typical depths range from 0.76 to 2.5 mm, and the corresponding width can be up to 25 mm. Advantages of this sampling technique (developed by Failure Analysis Associates^{6,3}) are reported to be a limited amount of material sampled, a good surface finish and the smooth geometry of the cut, which do not need a repair to be performed. Further, the clearance needed for the equipment is very reduced and the cutter may be remote controlled for sampling material from locations inaccessible by the operator.

A second equipment is suitable for removing straight longitudinal layers from pipes⁵ (Figure 2). A minimum thickness of 2 mm can be obtained, thus avoiding in most cases the need for repairing. This sampling method (developed by CISE, now CESI) is limited to straight pipes having a diameter of less than 450 mm and a free access length of at least 1 m.

3. Specimens for creep testing PE materials

The tendency to remove only small amounts of PE material in a non destructive way corresponds to the need for creep uniaxial specimens having reduced size or weld extended ends. The availability of only extremely reduced amounts of materials have also led to the adoption of creep testing techniques completely different from the typical uniaxial creep testing, such as small punch (or shear punch) creep tests^{3,6,5,9}. The use of such testing methods, as well as the use of weld extended or small-size specimens have to be validated.

In fact, standards on creep testing usually consider uniaxial creep specimens having a circular^{10,11,12,13} or rectangular cross section^{10,11,12,13}. They also fix for creep specimens:

- a minimum gauge length diameter which, according to the different standards, ranges from 3 to 6 mm (see also ref. 1, annex 1). Among the examined standards¹⁰⁻¹⁵ only ASTM standard¹⁴ mentions the importance of grain size on the limit of minimum diameter of creep specimen (this latter being not fixed 'a priori'). On the contrary, this standard imposes a maximum diameter of the gauge length.
- a minimum reference length, whose value can be fixed^{11,12} and/or related to the gauge diameter^{10,11,12} (see also ref. 1, annex 1,).

ECCC recommendations establish a minimum specimen gauge diameter of 5 mm for that is here referred as full-size specimen. They accept lower diameters when the 'source material' is a limiting

factor and when testing is to be performed in inert environment¹. The minimum gauge diameter rises to 6 mm for large grain sizes and for tests on weldments. In the same ECCC recommendations a minimum reference length 3 times the gauge diameter (5 times the gauge diameter is preferred) is fixed.

As previously mentioned, following the ECCC recommendations hereafter it will be considered a full-size specimen having gauge diameter $d_0 \geq 5$ mm and reference length $L_r \geq 3d_0$. A specimen having $3 \leq d_0 < 5$ mm will be referred as sub-size specimen while specimens having $d_0 < 3$ mm will be considered miniature specimens.

A remark can be made on sub-size and miniature specimens. They are used not only for PE materials, due to the above 'non destructivity' requirements, but also for characterisation of the creep behaviour of expensive materials, such as precious and rare earth alloys, continuous fibre MMC, ceramics and intermetallics¹⁶.

When creep specimens are used, particular attention is paid to the specimen diameter of the gauge length (d_0), since this is a particular limiting factor due to the amount, and particularly to the thickness, of the available PE material. Specimen diameter has relevant effects on the creep characteristics of the material that can be evaluated, in particular when a small diameter is used when misalignments or material/environment interaction.

These effects will be considered in a following paragraph. The gauge length also affects the creep rupture time. In fact, it was proved that low values of the gauge length/gauge length diameter ratio correspond to longer times to rupture due to restraint effects¹⁸. The effect can be neglected when the above ratio is greater than 3¹⁸, as for the sub-size and miniature specimens reported in the examined literature. A further effect of the gauge length is due to the presence of necking. When material ductility is relevant, the presence of necking will lead to the evaluation of greater elongation to fracture in specimens with a reduced gauge length¹⁸. Handling and machinability needs have also to be taken into account when designing specimens of reduced size. The common practice for miniature specimens (for example with diameter equal to 2 mm) is to machine gauge length of at least 10 mm.

3.1. Homogeneous sub-size and miniature specimens

Homogeneous sub-size and miniature specimen can have the typical geometry of full-size uniaxial creep specimens, with enlarged threaded ends. A usual diameter found in literature for miniature specimens is 2 mm^{2,5,16}. In this case the external diameter of the threaded ends of a specimen having $d_0=2$ mm is of 3.5-5 mm^{5,9}.

The requirements for a limitation of the material to be machined led to the design of different geometry. An example is the creep specimen having extremities with an enlarged solid bar profile. The diameter of the raw material needed to obtain such a sample having $d_0=2$ mm is 3.4 mm, thus with a reduction in the volume of PE material to be removed⁵.

Another step toward the miniaturisation of creep specimens can be considered the homogeneous sample having conical ends. In this case the raw material needed to machine a 2 mm do testpiece is only 2.5 mm⁵. Nevertheless load alignment has proved to be a limiting factor for the introduction of this sample geometry.

3.2. Weld-extended sub-size and miniature specimens

The reduction of material needed to prepare creep specimens can be dramatically reduced by means of weld extended sub-size or miniature specimens^{5,7}. In these cases a raw cylinder of PE material is welded to grips having a greater diameter made from different material (it may be the also the same, even if virgin, material). The welded raw specimen is then machined to its final shape (See, for example, Figure 4²). The whole reference length should be made of PE material, machined in a region where it is not affected by microstructural alterations brought about by the welding process, i.e. outside the HAZ (Figure 5⁷). The amount of PE material to be used is thus very reduced. For example the fabrication of such a specimen having 2 mm diameter requires a raw cylinder of 2,6 - 3 mm diameter^{5,10}. Particular care has to be taken to avoid misalignment of the welds.

The material of the weld extended ends has been defined as ‘identical’² to that of the gauge length, probably meaning a material having the same chemical composition. A discussion on the material to be used for in weld extended ends is reported in the ECCC Recommendations for creep testing of post-exposed (ex-service) materials.¹⁷

The welding processes often used to obtain weld-extended samples are electron beam and laser welding. Both are high-energy-density welding processes that can produce a deep, narrow and parallel-sided fusion zones and narrow heat affected zone. Further, these welding processes leave very limited angular distortion. Electron beam process is less expensive⁹, assures higher production rates and do not need to operate in vacuum². A drawback of this kind of specimens is also reported in literature⁵ and the use of weld extended specimen should be avoided for materials where welding could bring about brittle phases, such as for steels containing vanadium.

3.3. Mini-discs creep test (small or shear punch creep tests)

A further type of tests which has been introduced to study the mechanical behaviour of material when they are available in very small amounts such as in the case of PE materials obtained by means of some non destructive techniques⁶, is the mini-disc creep methods (shear punch or small punch tests). Here, a simple disc of material, supported around its periphery, it is subjected to a ram load at its centre³. The small punch methods, originally developed to estimate material fracture toughness², have then been modified to evaluate creep characteristics, by subjecting the disc to a fixed load by means of a hemispherical punch and monitoring, until rupture occurs, the relative displacement (more often, the relative displacement of the mobile to the fixed part of the loading train)^{8,3}. The disc diameter may range from 2 to 10 mm, its thickness between 0.2 and 2 mm^{3,5}. The disc may be clamped at its periphery or not. There are a series of points to be investigated before considering this technique reliable and to give results that can be directly related to those of uniaxial creep tests:

- effect of punch diameter/disc diameter and punch diameter/disc thickness³.
- effect of clamp loading³
- the correlation between the load applied to the punch, the diameter of this latter and the applied stress of a corresponding uniaxial creep test⁵. This is not of simple definition, because the stress state in a minidisc and in uniaxial creep specimens are different. An empirical correlation proposed for the applied stress is based on equivalent rupture times⁵.

4. Creep testing equipment for sub-size and miniature specimens

Focusing the attention on the testing procedures for obtaining creep data from uniaxial sub-size and miniature specimens, it can be observed that particular care should be used not only in the preparation of the specimens but also in their handling, in their positioning along the loading train and in the testing procedures. Further, the testing equipment should often be modified in order to perform reliable creep tests on these specimens. Creep testing machine as well as creep testing procedures and environment will be considered separately in the following paragraphs.

4.1. Creep testing machine

During creep tests of sub-size, and particularly of miniature specimens, the applied loads are smaller than when full-size specimens are tested. Thus, the use of modified creep machines or of particular testing equipment has been reported in literature.

The testing machine used can be a direct load machine where gravity alignment is allowed⁸. In this case small loads can be applied to the loading train and load errors due to tolerance on lever arm length and position are avoided⁸. The error on dead weights can be less than 0.5%^{2,9}.

4.2. Alignment of the specimen

The requirement of a good alignment of the creep specimen to the applied load is often reported in literature works by laboratories where creep tests are performed on specimens of reduced size. This requirement to specimens of reduced size is due to the fact that misalignment causes load increments, the importance of which is greater the smaller the specimen size. In fact, it has been experimentally verified that, when creep machines without particularly restrictive specifications on load accuracy are used, rupture times for specimens of greater diameter are longer than those of the corresponding specimens of reduced size (see Figure 6). Within the same experimental study, high precision constant stress creep machines were also used; in this case, no difference in rupture times of specimens having different diameters was noticed⁸. Further, the effect of specimen size was noticed to be greater when materials were tested under small stress levels (and, correspondingly, greater times to rupture). These effects were not explained on the basis of oxidation, since this latter would have led to greater reduction of rupture times at low applied stress levels⁸. On the contrary, load misalignment was supposed to be the cause of different rupture times. As mentioned above, the application of a non-axial loading adds to the creep specimen a local increase in stress ($\delta\sigma_b$), following the equation¹⁸:

$$\delta\sigma_b = 4 \sigma_0 e r^{-2} r^{1/n} \quad (1)$$

where (σ_0) is the applied stress, (e) is the misalignment, (r) is the specimen radius and (n) the stress exponent. Thus, the stress increment and, correspondingly, the reduction of creep rupture times of specimens of different size are greater the greater the applied stress and the smaller the specimen diameter. Load misalignment has also to be kept at sufficiently low values.

Some modifications of loading apparatus are proposed in the literature to limit bending effects^{2,5,8}. Despite the relative importance of bending stresses on small size specimens, no particular maximum bending value has been reported in the examined literature. As proposed in reference 17, an accurate alignment of the loading string and of the gripping ends should limit the bending stress within 20%. Elastic bending stresses could be measured by means of strain gauges attached on a specimen of the same geometry as those to be tested.

Torsion stress can also modify the results of creep tests. No particular value for minimisation of torsion stresses has been found in the examined standards, papers or laboratory practices. In the

case of specimens of reduced size, particularly miniature specimens, torsion forces such as those arising from gripping could result in torsion stresses of importance. When only axial applied stress σ_o and torsion stress τ are present, the Von Mises equivalent stress σ_e is $(\sigma_o^2 + 3\tau^2)^{0.5}$ and maximum principal direction does not coincide with the specimen longitudinal axis. Despite this latter difference with the case in which only bending effects were present, the same maximum value for σ_e (i.e. $1.2\sigma_o = \sigma_o + \sigma_{\text{bending max}}$) can be desirable. This results in a maximum torsion stress of $0.38\sigma_o$, as proposed in ref. 17 as future goal for the upper limit to torsion stresses.

4.3. Gripping equipment

Specimens of very small size, without threaded ends have to be located along the loading train by means of special grips. In the case of specimens without threaded ends the use of gripping systems based on cylindrical wedge have been reported in literature⁹. The materials of the wedges should guarantee limited oxidation and good mechanical properties for long times at the testing temperatures.

4.4. Strain measurement system

Strain measurement used when creep tests are performed on sub-size or miniature specimens are seldom mentioned in literature. This could implicitly mean that conventional strain measurement devices are used (extensometers placed diametrically). When it is not possible to measure directly the elongation of the reference length, the relative displacement between the fixed part of the loading train and its mobile part can be measured and the strain can be evaluated by means of a model of the mechanical behaviour of that part of the loading train of interest. Such a device is used, for example, when vacuum or environmental chambers are used. In those cases, the strain is indirectly evaluated.

5. Environmental effects on the results of creep tests

The environment in which the test is carried out can affect the creep characteristics of the material, if the effect of the interaction between the material and the atmosphere is significant. This interaction could also be affected by the stress state of the material. The altered material has also a modified mechanical behaviour with respect to the material at the beginning of the test, in particular in the external surface region of the specimens. The material/environment interaction can be of different type and also lead –in principle - either to material softening or hardening.

The level of microstructural alteration and the thickness of the material/environment interaction layer are of significant importance for creep data obtained from specimens of reduced cross-section, particularly when they are crept at low stress levels (corresponding to long-term tests).

5.1 Oxidation effects on creep curves

The most common form of the material interaction with the environment is oxidation. Its effect on creep curves has been evaluated for example, by Roy and Gosh¹⁹. They also proposed a simple model to take into account the effect of specimen geometry and oxidation. The geometric effect is due not only to the specimen cross-section but also on section geometry, since oxidation takes place along the external surface of the specimen. The hypotheses of the model are:

- homogeneous oxidation on the specimen surface,
- no contribution of the oxide layer to the load bearing capacity of the specimen (because of the brittleness of the oxide layer)

When an oxide layer of thickness x covers a cylindrical specimen the ratio of the current stress (σ) to that of the stress to which the specimen would be subjected in the absence of the oxide layer (at the beginning of the test) (σ_0) can be calculated as follow¹⁹:

$$\sigma/\sigma_0 = 1/(1-x/r)^2 \quad (2)$$

The current stress due to oxidation can thus be evaluated as a function of oxidation time once the oxidation kinetics is known and its value can be inserted in a law of accumulation of creep strain to model the creep behaviour of a specimen in which oxidation takes place.

In the case of small thickness of the oxide layer compared to specimen diameter the ratio between the stress increment due to oxidation and the initial stress of the specimen $\Delta\sigma$ (oxide thickness = 0) can be evaluated in an approximate way, as:

$$\Delta\sigma/\sigma_0 = A_{ox}/A_0 \quad (3)$$

where the parameter A_{ox}/A_0 is the ratio between the oxide layer area A_{ox} (i.e. layer thickness * specimen perimeter) and the cross section area A_0 (considered at the beginning of the test)¹⁷. In this way, under the above hypotheses, a linear correlation between the thickness of the oxide layer and the stress increment can be considered.

The table below lists the thickness t of the oxidised external layer of metal giving rise to stress increments ($\Delta\sigma/\sigma_0$) estimated by the equation proposed by Roy and by that proposed in [17] in cylindrical testpieces of different diameter d_0 .

Diameter d_0	Oxide thickness t (mm)	$\Delta\sigma/\sigma_0$ [ref.19] (%)	$\Delta\sigma/\sigma_0$ [ref.17] (%)
10	0.250	10.80	10
5	0.125	10.80	10
3	0.075	10.80	10
2	0.050	10.80	10
10	0.125	5.19	5
5	0.063	5.24	5
3	0.038	5.27	5
2	0.025	5.19	5
10	0.050	2.03	2
5	0.025	2.03	2
3	0.015	2.03	2
2	0.010	2.03	2
10	0.025	1.01	1
5	0.013	1.05	1
3	0.008	1.08	1
2	0.005	1.01	1

The presence of oxide, leading to an increase in applied stress, reduces rupture times with respect to those obtained in inert environment. The reduction of rupture time with respect to tests carried out

in inert environment is greater the smaller the specimen size. A temperature effect has also to be taken into consideration. Different methods have been proposed to evaluate the rupture time of unoxidized specimens on the basis of rupture times of oxidized specimens times^{7, 20, 21}.

The combination of environmental effects and specimen diameter has been investigated by Borggreen and Huntley^{7, 20}. According to Borggreen and Huntley the ratio between rupture time of oxidised specimen (t_{air}) and that of a test carried out in inert environment ($t_{inert\ gas}$) is a function of the oxide thickness at the end of the test in air and of the specimen size (diameter d or radius r).

$$t_{air}/t_{inert\ gas} = ((d-2x)/d)^{2n} = [(1-x/r)^2]^n \quad (4)$$

According to eq. (2) $[(1-x/r)^2]$ is the ratio between the initial applied stress σ_0 and the current stress σ . In this model the oxide thickness can be obtained only when the rupture time of oxidised specimen is known, using for example a parabolic growth law:

$$x = (K_p * t)^{0.5} \quad (5)$$

where K_p is a temperature-dependant parameter.

The oxide thickness at the end of the test could be also estimated on the basis of oxide growth rate of PE material at test temperature and of the test duration. The way proposed by TGL Standard is to use (without specifying for what material or steel grade) a time-temperature parameter:

$$P = 11360/T - \log(t) \quad \text{where } t \text{ is evaluated in hours, } T \text{ in Kelvin} \quad (6)$$

The parameter P can be used to estimate the thickness of metal loss x as:

$$\log(x) = -a * P + b \quad \text{where } a \text{ and } b \text{ are constants for the tested material.} \quad (7)$$

The method proposed by TGL standard accounts for the presence of the oxide thickness by correlating the actual rupture time to a 'corrected' stress. The 'corrected' stress is the stress that, in the absence of oxidation (or of other environmental effects), would have led to the same time to rupture of the specimen where metal loss x has been observed at the end of the test. Following the TGL Standard the corrected stress corresponds to the average stress between the current stress at the beginning and end of the test:

$$\sigma_{corr} = [\sigma_0 + \sigma * (1/(1-x/r)^2)]/2. \quad (8)$$

Another way to estimate the effect of oxidation on the results of creep test can be obtained by considering the following simple model, under the hypotheses of stationary creep, constant stress (i.e. stress increase due to specimen elongation compensated by reduction of applied load) and of cross-section reduction due to metal loss. The current (effective) stress can thus be evaluated as in eq. (2). If the material deforms by a power-law equation of the form:

$$\dot{\epsilon} = \dot{\epsilon}_0 \left(\frac{\sigma}{\sigma_0} \right)^n \quad (9)$$

then the strain rate dependence on the metal-loss layer of thickness x , is the following:

$$\dot{\epsilon} = \dot{\epsilon}_0 \left(\frac{1}{1-x/r} \right)^{2n} \quad (10)$$

The model assumes also a parabolic time dependence of the metal-loss layer thickness x (equation 5). The stress increase due to oxidation has been evaluated for a 9Cr1Mo steel at 723 and 873K, for specimen of different radius of the gauge length: 5, 2.5 and 1 mm (Figure 7a). Material data for oxidation of the 9Cr1Mo steel have been found in literature²². The effect of oxidation increases as

the time and temperature increase and specimen size decreases and it has clearly to be taken into account for long-term creep tests.

When no oxidation takes place the time to reach a fixed strain (or rupture, if it is considered to occur at fixed strain and without the onset of tertiary creep stage) corresponds to the ratio between this strain and the creep strain rate (hereafter referred as ‘no-oxidation time’ and in the y-axis in Figure 7b). As the oxidation effect increases (i.e. temperature or test time increase, or specimen size decreases) the ‘no-oxidation time’ becomes increasingly higher with respect to the time in the presence of oxidation effects (referred as ‘real time’ and displayed in abscissas in Figure 7b). The ratio between ‘real time’ and ‘no oxidation’ time can be considered as an oxidation correction factor. Once it is known the oxidation correction factor for a miniature specimen, tested at a specific temperature and with a certain time to rupture (a ‘real time’), the corresponding time to rupture (‘no oxidation time’) of a specimen that does not suffer oxidation effect (due to testing environment or to its large size) can be calculated by the ratio between ‘true’ rupture time and correction factor.

Thus, the three modes to evaluate the ‘corrected’, or ‘no-oxidation’ time to rupture (without oxidation effect) or time corresponding to a fixed creep strain are similar in considering the stress increase due to oxidation. Nevertheless, they evaluate differently the ‘corrected’ time on the basis of an average stress [ref. 21], of the final stress [ref. 7 and 20], or the evolution of stress with time and oxidation (present model). The ‘corrected’ times can widely differ when heavy oxidation takes place during the creep test. For example, when the only stress increment at the end of the test is used to evaluate the corrected time (as in the method proposed by Borggreen), the correction factor can be underestimated, and thus ‘corrected’ (no-oxidation’) times in non oxidising environment can be overestimated, since for most of the creep life the effective stress acting on the specimen was lower than the calculated one. This is evident when a comparison of correction factors displayed in Figure 7c and 7d is made.

5.2 Laboratory practices to reduce oxidation effects

The use of inert gas or vacuum is usually taken into account in laboratory practices [2,9,16,18] in order to avoid excessive surface material alteration, particularly when miniature specimens are used. Argon is commonly used, even if helium with a purification system has also been reported in literature²⁰. Other particular atmospheres can of course be used when the interaction with such environments is specifically required to pursue the aim of the research.

The reduction of environmental effects by means of testing in particular atmospheres in some cases revealed to have negative effects on the material. The case of decarburization of a low alloy piping steel reported by McCarthy¹⁶ (explained as a result of the presence of residual moisture inside the chamber containing argon) is the example usually cited in the literature. In the mentioned case the negative effects were eliminated using a vacuum chamber maintained at $6 \cdot 10^{-3}$ mbar.

Different environment and test procedures are also reported in the examined literature. Some laboratories perform creep tests in inert static argon, but only after reaching a high vacuum level in the chamber (10^{-6} mbar is the value reported in ref. 2) with the aim of eliminating the presence of moisture inside the chamber. Another, quite common laboratory practice is the use of a gas chamber where a stream of argon is slowly flowing.

The evaluation of the suitability of the environment used for creep test is often done by comparing creep rupture times of specimens tested in different atmospheres (or following different test procedures) (see for example Figure 8) without taking into account the degree of environment/atmosphere interaction, for example by means of oxide layer thickness measurement or by hardness measurements.

6. Creep testing practices for PE materials

No particular procedure has been specifically described in literature for creep testing of PE materials and, in particular, for sub-size and miniature specimens. The need of a careful handling of specimens during their mounting on the loading train is quite obvious. The same can be said for the mounting phase of the strain measurement system and for the of load application, during which any shock should be avoided.

7. Conclusions

The review described the techniques for sampling and creep testing Post-Exposure (PE) materials presented in literature. Since creep testing data on these materials are of great importance in life assessment of components, particular attention and care have to be paid not only to the execution of the test itself, but also to the sampling methods and to some characteristics of the creep specimen. Several features of material sampling, specimen preparation as well as of the creep testing practice have been taken into consideration. The effects of sample size, creep specimen geometry and specimen preparation, of creep testing equipment (in particular load alignment and bending/torsion tolerances) and of testing procedures have been discussed. Finally, the effect of the material interaction with testing environment has also been discussed and some models for the estimation of oxidation effects have been reported.

8. References

1. ECCC Recommendations Volume 3 Part I, 2001, "Data acceptability criteria and data generation: Generic recommendations for creep, creep rupture, stress rupture and stress relaxation data", (issue 5), edited by J. Granacher & S.R. Holdsworth, Published by ERA Technology Ltd, Leatherhead.
2. A. Garzillo, C. Guardamagna, L. Moschetti, L. Ranzani. "A technique for the residual life assessment of high temperature components based on creep rupture testing on welded miniature specimens", *Int. J. Pres. Ves. & Piping*, 66 (1996), 223-232.
3. J.D. Parker, B. Wilshire, "Non-destructive Life Assessment of High Temperature Components and Weldments", *Int. J. Pres. Ves. & Piping*, 50 (1992), 337-347.
4. ECCC-MC "Memorandum of Understanding of European Creep Collaborative Committee", ECCC Document N. 5224/MC/87.
5. V. Bicego, M. Certo, C. Sanpietri, F. Bregani, "Non destructive material creep damage evaluation in service exposed components: ENEL experience", Presented at EPRI-workshop "NDE for Damage Assessment", 6-7 Oct. 1997, Lajoll (California).
6. D. Mercaldi, J. Parker, "Material sampling for rotor evaluation", EPRI Conference "Assessment of turbine generators", Charlotte (North Carolina), 1989.
7. K. Borggreen, J. Soresund, "Remanent Life Assessment by Use of Miniature Creep Test Specimens". Final Report for the Nordtest Project 1035-92, Force Institut (Copenhagen) (1995).

8. E. Lucon, S. Tettamanti, L. Ranzani, "Le prove meccaniche su campioni miniaturizzati: finalità, tecniche e affidabilità dei risultati", Workshop "Prove meccaniche sui materiali metallici", Milan, 10 Dec. 1997.
9. S. Tettamanti, N. Taylor A. Garzillo "Creep damage evaluation via accelerated tests and microstructural analysis", Proc. Euromat '95, Padua-Venice, 1995, 617-620.
10. BS 3500, "Methods for creep and rupture testing of metals; Part 3, creep rupture testing". British Standards Institution, 1969.
11. EN23-75 "High Temperature Tests. Creep tests for steel", 1975.
12. DIN 50118 "Zeitstandversuch unter Zugbeanspruchung", 1982.
13. UNI 5111-69 "Prove meccaniche dei materiali ferrosi. Prova di scorrimento a temperature elevate per l'acciaio".
14. ASTM E 139-96 "Standard Test Methods for Conducting Creep, Creep Rupture, and Stress-Rupture Tests of Metallic Materials", 1996
15. ISO R 204 "Non-interrupted creep testing of steel at elevated temperatures", 1961.
16. P.R. McCarthy, J.M. Brear, "Successful miniature specimen testing: a case study" Proc. fifth Int Conf. "Creep and Fracture of Engineering Materials and Structures", Swansea, 28/3-2/4 1993, 661-670.
17. ECCC Recommendations – Data acceptability criteria and data generation : Recommendationd for creep testing of post-exposed (ex-service) materials. In ECCC-WG1 Recommendations "Data validation and assessment procedures", Volume 3, Part III (issue 1), edited by E. Gariboldi, Published by ERA Technology Ltd. Leatherhead, 1999.
18. J.D. Parker, "The effect of specimen size on creep behaviour". Rivista Italiana della Saldatura, Vol. 48, No 6, (1996), 609-617.
19. N. Roy, R.N. Ghosh, "Modelling effects of specimen size and shape on creep of metals and alloys", Scripta Materialia, Vol.36, n.12 (1997), 1367-1372.
20. K. Borggreen, P. Huntley, "Some environmental effects on creep testing and extrapolation using minor specimens".
21. TGL 11224 – Prüfung metallischer Werkstoffe Zeitstandversuch, December 1977
22. J. Armitt, R. Holmes, M.I. Manning, D.B. Meadowcroft, E. Metcalfe. "The spalling of steam-growth oxide from superheater and reheater tube steels", CERL FP-686 Technical Planning Study 76-655 (1978).

9. Figures

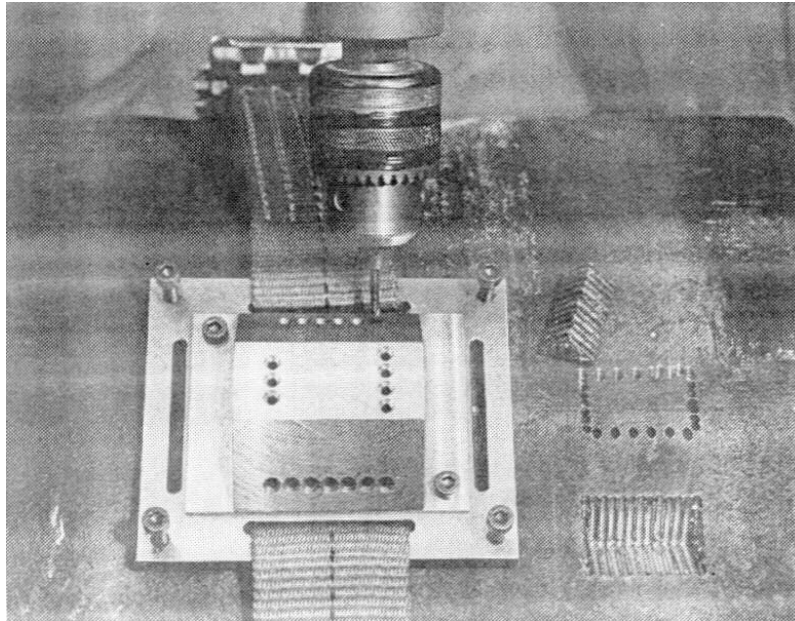

Figure 1. An example of removal of PE material by means of drilling jig, as presented in ref.7.

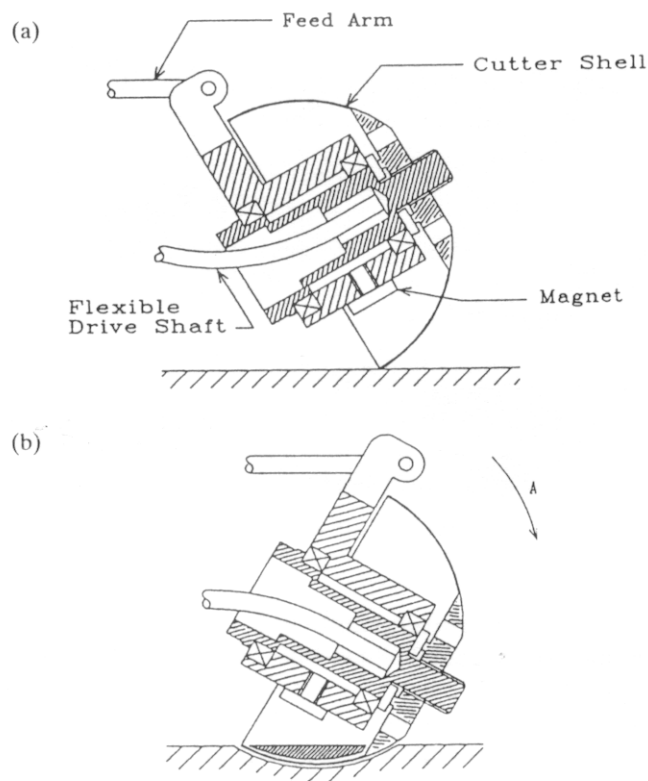

Figure 2. Sampling method proposed in refs. 6, 3.

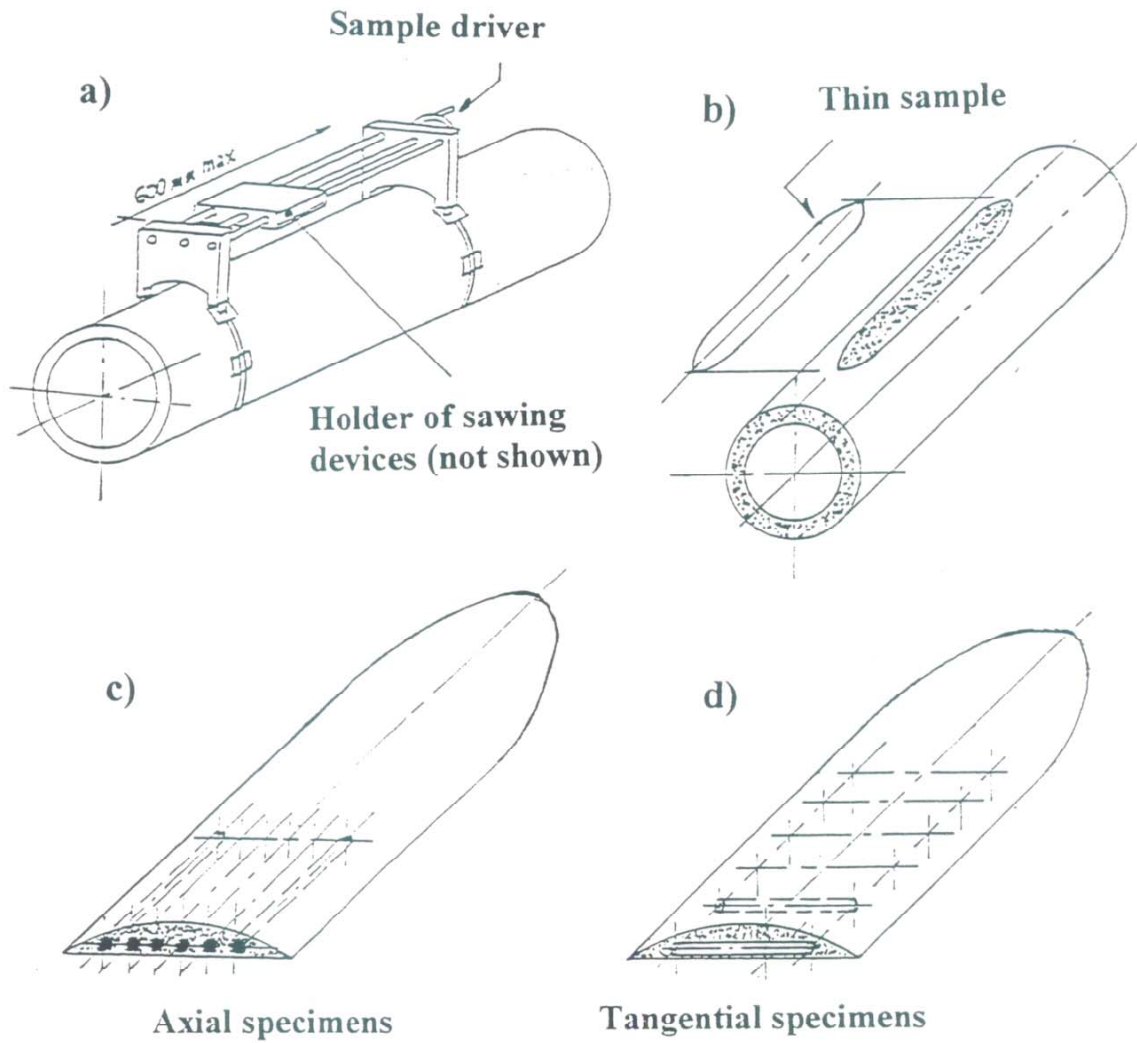

Figure 3. Sampling method proposed in ref. 5.

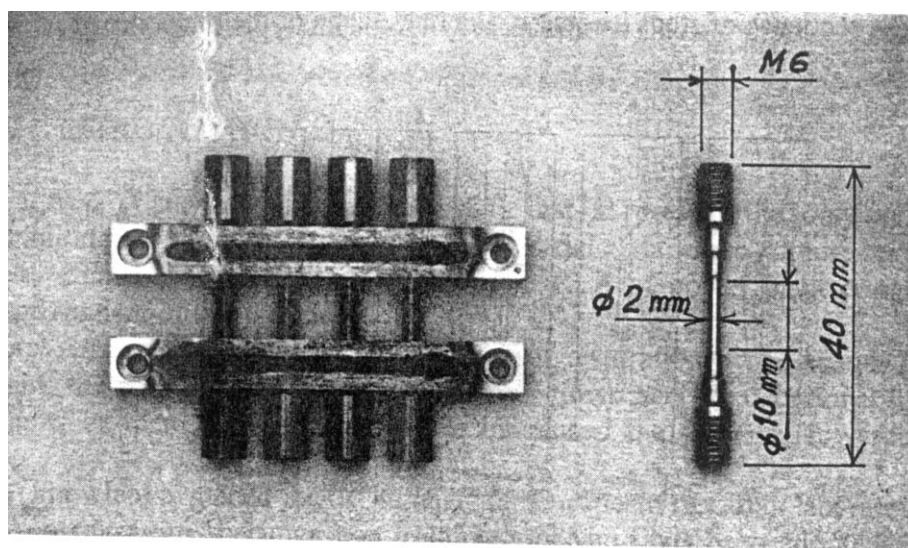

Figure 4. Weld-extended miniature specimens presented in ref. 2

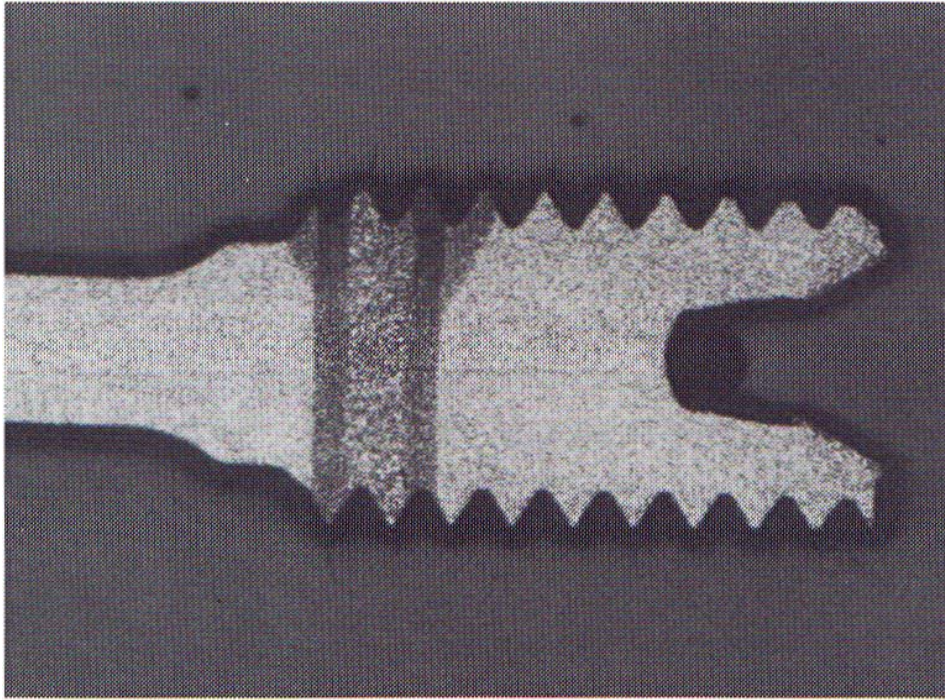

Figure 5. The electron beam welded creep specimen where the weldment lies inside the threaded ends (Ref. 7).

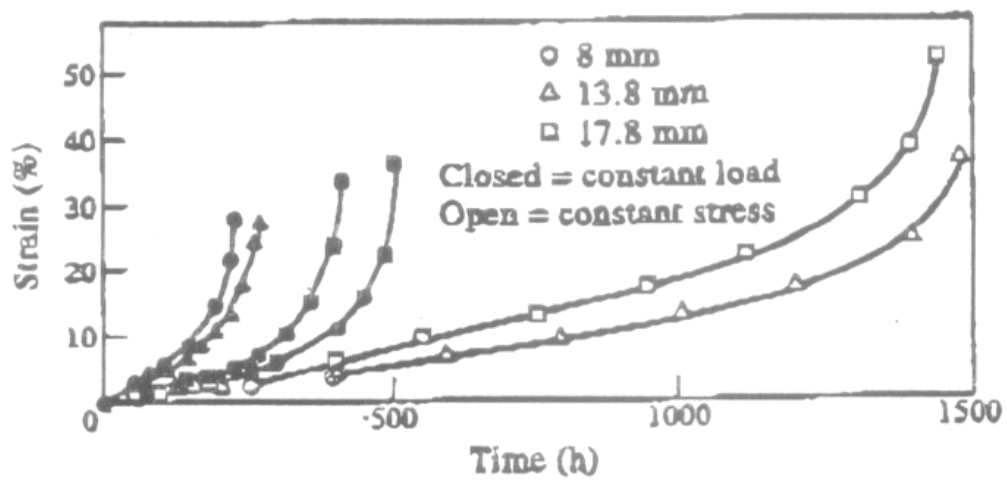

Figure 6. Effect of specimen size on the creep rupture times of CrMoV specimens having different diameters of the gauge length (Ref. 18).

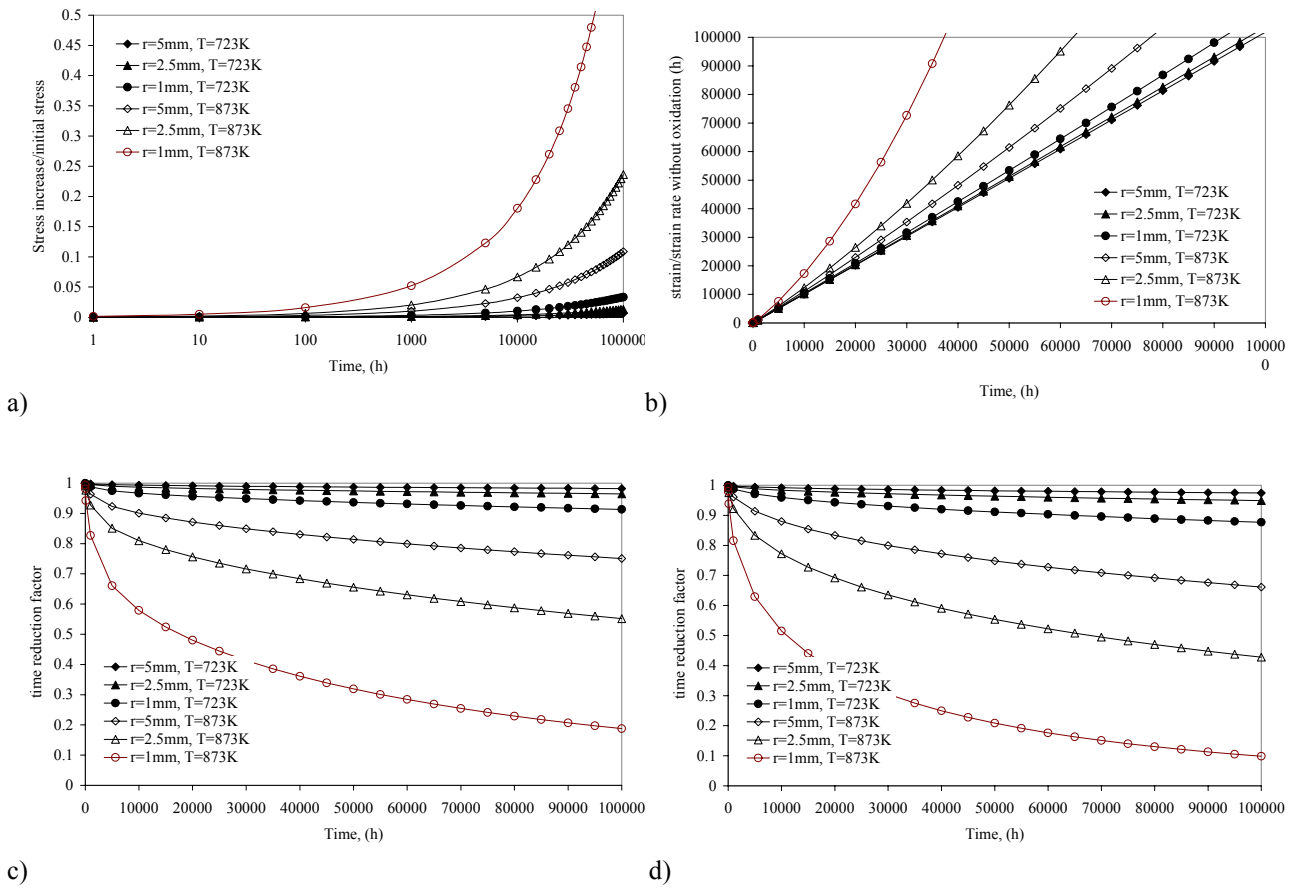

Figure 7. Effect of oxidation on the stress increment (a), on the ‘corrected’ or ‘no-oxidation’ time (y-axis) (b), on the time correction factor to estimate the reduction of test time due to specimen oxidation in the present model (c) and using the method proposed by Borggreen and Huntley, where time in abscissas correspond to rupture time (d). In all the diagrams time in abscissa correspond to the ‘real time’ in the presence of oxidation.

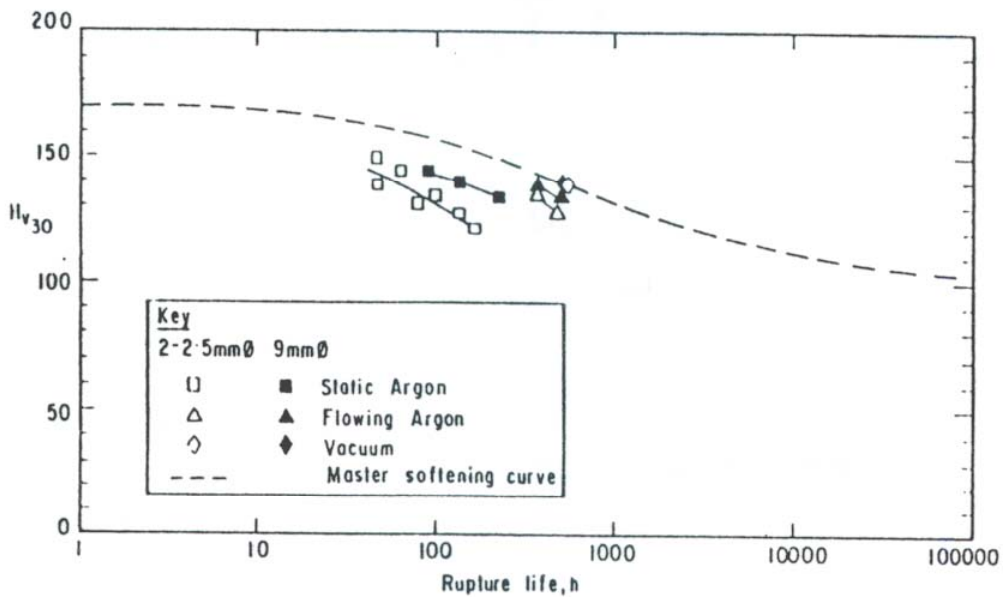

Figure 8. The effect of testing atmosphere on creep rupture time reported in ref 16.

APPENDIX 3
SPECIFIC CREEP TESTING TECHNIQUES FOR PE MATERIALS

S Brett [RWE npower, UK]

CONTENTS

- App. 3a: Small Scale Conventional Creep Testing (G. Merckling)
- App. 3b: Impression Creep (T. Hyde)
- App. 3c: Small Punch Creep (Z. Kubon)

blank page

Appendix 3a

Small-Scale “Conventional” Creep Testing

Gunther Merckling – Istituto Scientifico Breda

The aim of the application of such a testing technique is to provide creep strength and strain values for direct use in design from serviced exposed material, from which sampling to produce full size specimens is not possible without hindering plant operation.

Material Sampling

The technique consists of the production of a series of creep test specimens of reduced size, machined from material samples that can be taken from the component without limiting its serviceability, e.g. cut from the redundant wall thickness of a pipe. As, generally, a creep campaign consists of 4 to 6 specimens, samples of ca. 100mm x 50mm x 2-3mm are more than sufficient. Sampling methods have been described in the literature, where saws, drillers, core drillers and electro-discharge portable sampling machines have been reported.

Specimens:

Typically miniature specimens are ca. 50-70mm long, with a gauge length of 16 - 20mm and a gauge diameter between 0.8 and 2mm. Normally the detailed test piece geometry is adapted to the available material sample, in order to use as much material as possible for each specimen. The material from the component damaged by the sampling process however has to be carefully excluded from the gauge length. Depending on the size of the available material and testing facilities, “constructed” specimens have also been used, where the gauge length machined from serviced material has been welded to heads obtained from similar virgin material. The welding processes used for this have been laser and electron beam welding, and occasionally very controlled Tungsten inert gas welding. In any of these cases, the specimen must be designed in such a way, that the weld does not influence the gauge length creep behaviour and that it is guaranteed that failure will not occur around the weld.

Testing requirements

In principle the requirements for miniature specimens are similar to those for conventional creep testing, as detailed in the ECCC Recommendations for Creep Data Generation [2]. There are however some additional requirements, which are detailed in Volume 3 part III of the ECCC recommendations. Among the most relevant testing equipment requirements are:

- severe control of misalignment, as the small specimen, particularly if made of heavily aged material, is very sensitive to the additional stresses induced by bending and/or torsion. If “constructed” specimens are used care must also be taken to ensure that such stresses do not affect the welding.
- the interaction of creep behaviour and oxidation is not negligible (Figure A1.1), particularly if tests are accelerated by temperature. Due to the very tiny gauge diameter, failure due to specimen oxidation could dominate failure by creep. This generally requires testing equipment incorporating either inert gas (argon, helium, etc.) or vacuum chambers to protect the specimen. Additional gauge length protection with “getter materials” is also good practice. Experiments have also been carried out with plated or coated microspecimens, but interaction between substrate and coating must then be taken into account.
- due to the presence of the argon or vacuum device, assembling, loading and oxidation protection need to be very precisely co-ordinated and integrated, in order to avoid not only bending and oxidation, but also humidity entrapment in the chamber during the mounting of the specimen.
- strain measurement becomes complex due to the small gauge length, the non availability of collars around the gauge length and the presence of the oxidation protection features. As a result mainly simple stress-rupture tests are performed. Where strain is required, this is

measured outside the furnace or by expensive extensometers reaching through the chamber.

Testing Program Setup

Due to reduced amount of material and specimens, due to the relatively complex testing method, and also due to the urgency that often accompanies residual life estimation activities, miniature specimen test programs usually involve accelerated testing methods. Those employed most frequently are:

- Isostress methods (tests are performed at stresses typical of service stress but at temperatures higher than those in service. Linear extrapolation in a $\log(\text{stress}) - \text{temperature}$ plot has shown to be possible, Figure A1.3).
- Parametric methods (tests are performed with appropriate stress and temperature combinations to produce a segment of the $\log(\text{stress})$ vs. parameter (mainly Larson-Miller) curve around the future service target, Figure A1.2).

Correlation with “conventional” creep results

All results reported in the literature show very good agreement between the creep rupture results of miniature specimens and those of conventional sized ones (eg see Figure A1.2). In some cases sensitivity associated with oxidation or the quality of oxidation protection (Figure A1.3), bending misalignment and sampling contamination have led to discrepancies. It should also be noted that, if the material is coarse grained, or if the specimen gauge diameter decreases significantly during testing, the material present in the gauge length cross section cannot be regarded as representative of the bulk.

Advantaged and disadvantages

The main advantage of micro specimen testing is the immediate applicability of the results to a design or residual life analysis. The disadvantages are relatively expensive specimen preparation and a complex testing technique requiring some “enhancement” on conventional creep testing machines. In addition the creep testing “uncertainties”, such as allowable creep strength extrapolation range and method, apply in full to miniature specimen testing.

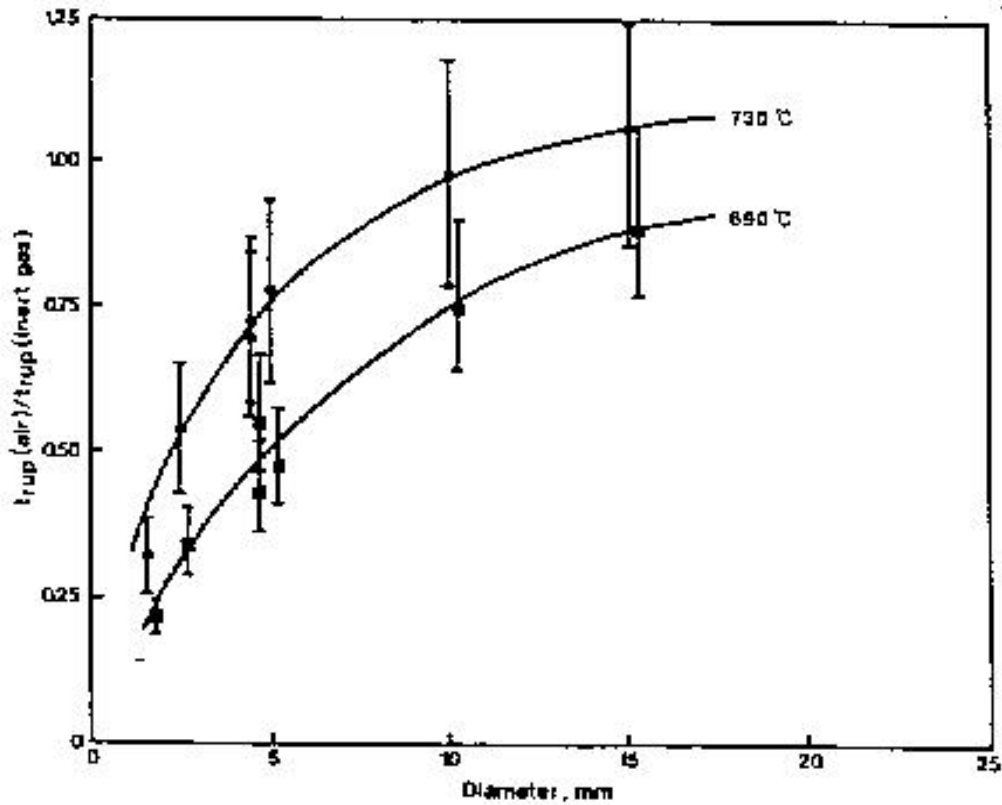

Figure A1.1: Effect of oxidation on creep rupture time depending on specimen diameter [1]

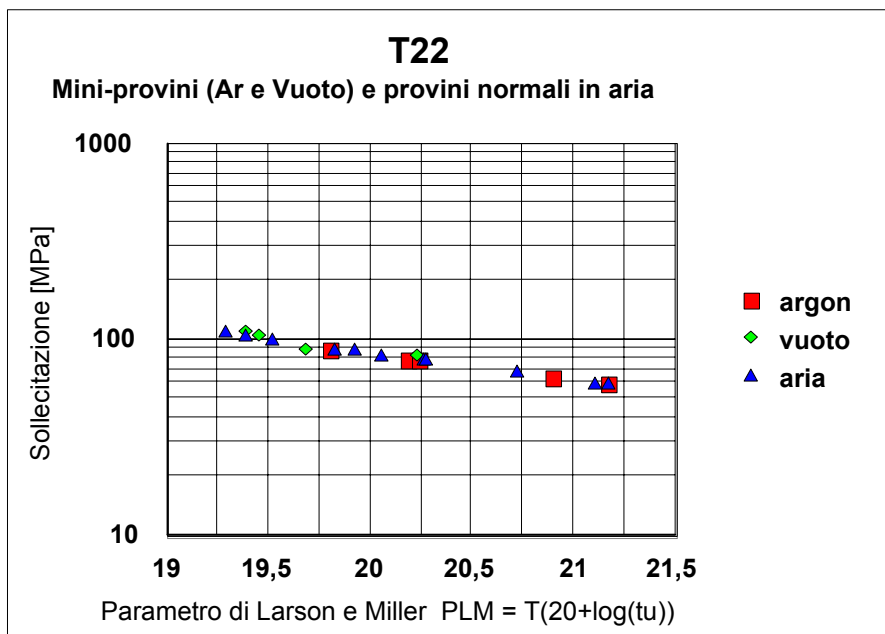

Figure A1.2: Comparison of Larson-Miller parametrised creep rupture strength of virgin 2,25Cr-1Mo conventional specimens tested in air (triangles), microspecimens tested in Argon (squares) and in vacuum (rhombi) [3]

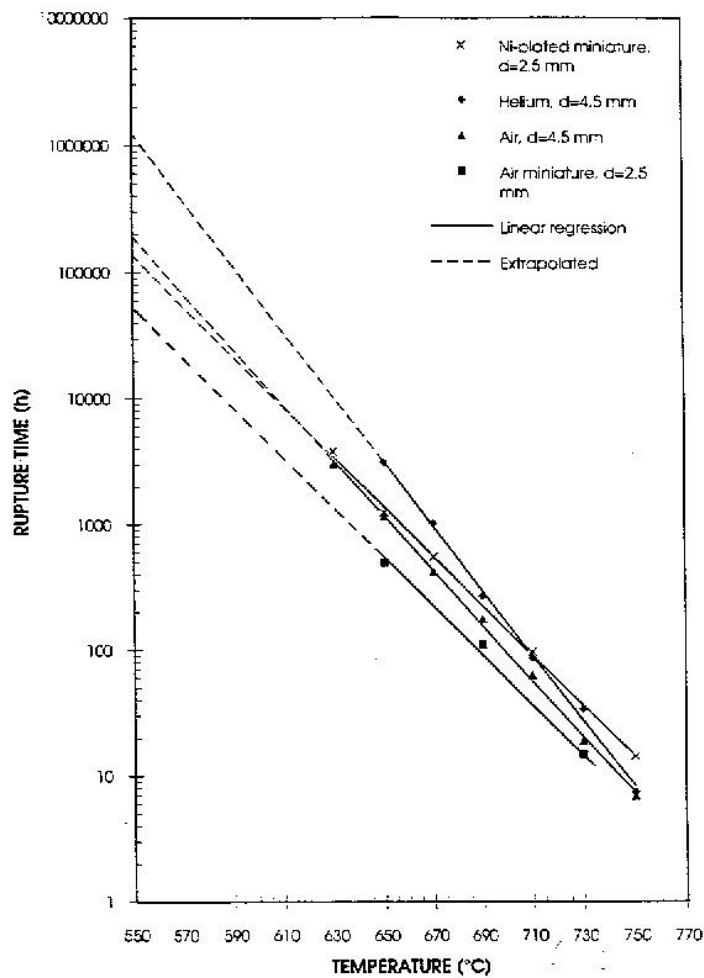

Figure A1.3: Efficiency of oxidation protection methods for microspecimen testing [1]

References

- [1]: Borggreen K, Storesund J, Remanent Life Assessment by Use of Miniature Creep Test Specimens, FORCE-Institut report 95.09.
- [2]: ECCRC Recommendations Volume 3, 2001, 'Recommendations for data acceptability criteria and the generation of creep, creep rupture, stress rupture and stress relaxation data', Eds. Granacher J., Holdsworth S.R., Klenk. A., Buchmayr B. & Gariboldi E., Publ. ERA Technology Ltd., Leatherhead, UK, (a) Part I: Generic recommendations for creep, creep rupture, stress rupture and stress relaxation data, (b) Part II: Creep data for welds, (c) Part III: Creep testing of PE- (ex service) materials.
- [3]: A. Garzillo, C. Guardamagna, L. Moscotti, A. Ranzani, A technique for the residual life assessment of high temperature components based on creep rupture testing on welded miniature specimens, Int. J. Pres. Ves. & Piping, 66 (1996), 223-232.

Appendix 3b

Impression Creep

Tom Hyde – University of Nottingham

The impression creep testing technique involves the application of a steady load to a flat-ended indenter, placed on the surface of a material at elevated temperature [1-4]. The displacement-time record from such a test is related to the creep properties of a relatively small volume of material in the immediate vicinity of the indenter. The indenter can be cylindrical or rectangular, and for these types of indenters, it has been shown [3,4] that the reference stress approach can be used to convert the mean pressure under the indenter, \bar{p} , to the corresponding uniaxial stress, σ , i.e.

$$\sigma = \eta \bar{p}$$

and to convert the creep displacement, Δ^c , to the corresponding uniaxial creep strain, ε^c , i.e.

$$\varepsilon^c = \frac{\Delta^c}{\beta d}$$

where η and β are conversion parameters and d is the diameter of the cylindrical indenter or the width of the rectangular indenter, Figure A2.1(a). The method of determining the η and β values has already been fully described previously [3,4]. The primary and secondary creep properties can be obtained by using impression creep tests. In this case, the technique only produces accurate results when the impression creep deformation achieved during the tests are very small, compared with the indenter width and the specimen thickness. Experimental results have shown that reasonably accurate creep properties can be obtained from impression creep tests for a number of metallic materials [5-8]. Figure A2.2 shows an example of the impression creep deformation with time for a HAZ material in a CrMoV weldment. Figure A2.3 shows examples of the minimum creep strain rate data obtained from uniaxial and impression creep tests for 316 stainless steel at 600° C [5,6] and a 2-1/4Cr1Mo weld metal at 640°C [7], using a rectangular indenter and the test samples shown in Figures A2.1(b) and A2.1(c). It can be seen that the data obtained from the two types of creep tests are in good agreement. In addition, multi-step load impression creep test technique [9] has been devised for the purpose of obtaining maximum creep deformation data from a single sample testing.

Impression creep testing is not necessary if a sufficient volume of the test material is available to manufacture uniaxial test specimens. However, in some practical cases, only very small amounts of test material are available, such as in the cases of in-service assessment of high temperature components, where small button-shaped samples (~ 25mm in diameter and 2-6mm in thickness) are removed by non-destructive sampling technique [e.g. 10]. Therefore, for these special cases, it is necessary to develop a small sample creep testing technique which can be used to produce the maximum amount of information from a very small volume of test material.

One particularly important application of the impression creep testing technique is in determining the creep properties at local positions where variations of creep properties exist, such as in the parent, heat-affected zone and weld metal of a fusion joint [4]. In weld situations, since the heat-affected zones are very narrow, the direct determination of the material creep properties in these regions, using conventional uniaxial tests, is not possible. However, care must be taken to ensure that the contact area between the indenter and the test material is large enough, compared to metallurgical features (e.g. grain size), to ensure that characteristic, bulk properties are obtained. For this reason, a long, rectangular indenter, as indicated in Figure A2.1(a), rather than a cylindrical indenter, is preferable. As well as the obvious benefit of increasing the contact area, the resultant increase in the applied load levels is of benefit.

References

1. Chu, S. N. G. and Li, J. C. M. (1977) Impression creep; a new creep test, *J. Mat. Sci.*, **12**, 2200-2208.
2. Gibbs, W. S., Aikin, R. M., Martin, P. L. and Patterson, R. A. (1990) Impression creep characterisation of Ti Al weldments, *Proc. 4th Int. Conf. on Creep and Fracture of Engineering Materials and Structures*, Swansea, 227-286.
3. Hyde, T. H., Yehia, K. A. and Becker, A. A. (1993) Interpretation of Impression Creep Data Using a Reference Approach, *Int. J. Mech. Sci.*, **35**, 6, 451-462.
4. Hyde, T. H., Sun, W. and Becker, A. A. (1996) Analysis of the impression creep test method using a rectangular indenter for determining the creep properties in welds, *Int. J. Mech. Sci.*, **38**, 10, 1089-1102.
5. Hyde, T. H., "Creep Crack Growth in 316 Stainless steel at 600° C", High Temperature Technology, Vol. 6, No. 2 (1988), 51-61.
6. Sun, W., "Creep of Service-Aged Welds", PhD Thesis, University of Nottingham, (1996).
7. Hyde, T. H., Sun, W., Becker, A. A. and Williams, J. A., "Creep continuum damage constitutive equations for the parent, weld and heat-affected zone materials of a service-aged 1/2Cr1/2Mo1/4V: 2 1/4Cr1Mo multi-pass weld at 640° C", *J. of Strain Analysis*, Vol. 32, No. 4 (1997), 273-285.
8. Hyde, T. H., Sun, W. and Williams, J. A., "Creep behaviour of parent, weld and HAZ materials of new, service-aged and repaired 1/2Cr1/2Mo1/4V: 2 1/4Cr1Mo pipe welds at 640° C", *Material at High Temperatures*, 16 (3) (1999), 117-129.
9. Hyde T. H. and Sun W., Multi-step load impression creep tests for a 1/2CrMoV steel at 565° C, *Strain*, 2001, **37**, pp. 99-103.
10. Parker, J. D. and Purmensky, J., "Assessment of performance by monitoring in service changes in material properties", 9th Euro. Conf. on Fracture, Reliability and Structural Integrity of Advanced Materials, Varna (1992).

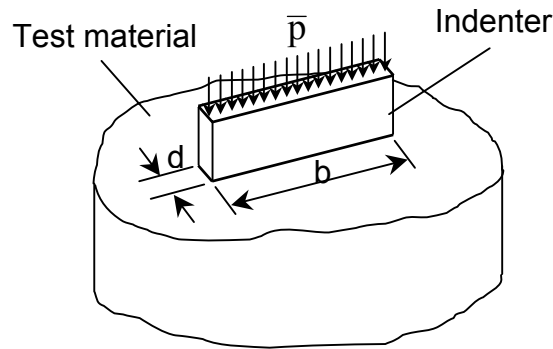

(a) schematic diagram of impression creep test with a rectangular indenter

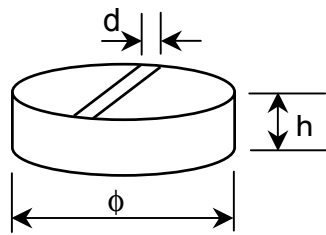

(b) cylindrical specimen

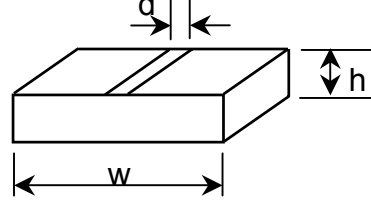

(c) square specimen

Figure A2.1 Impression creep testing and test specimens

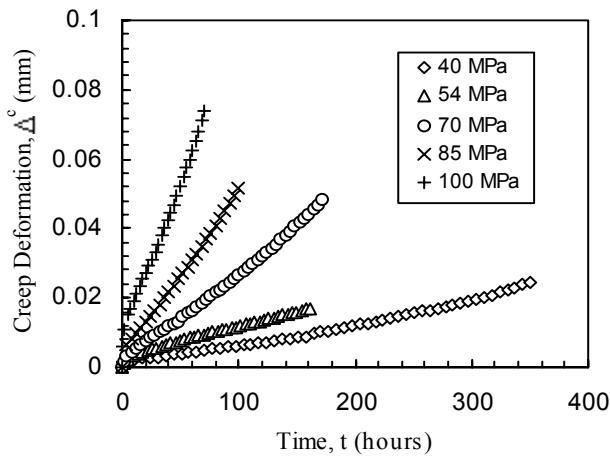

Fig.A2.2 Creep deformation from impression creep tests for the HAZ material in a 2-

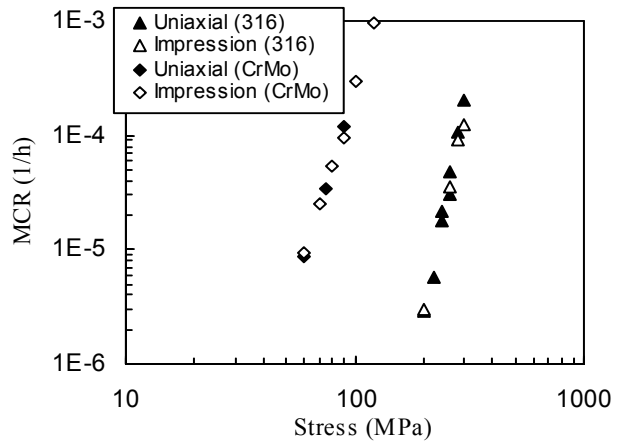

Fig.A2.3 Minimum creep strain rates for 316 stainless steel at 600°C and 2-1/4Cr1Mo weld metal at 640°C, obtained from uniaxial and

Appendix 3c

Small Punch Creep

Zdenek Kubon - Vitkovice

Constant rate of penetrating test (CRP)

The small punch test method pushes a loaded penetrator through thin specimens of the tested material. The sample is either simply supported or clamped between two dies and a cylindrical punch is led, via concentric holes in the upper and lower dies, across the tested material (Fig. A3.1). The monitoring load - displacement data obtained during the test make it possible to determine stress - ductility dependence (see Fig. A3.2).

Experimental testing has been performed using two testing methods - Bulge and Shear tests:

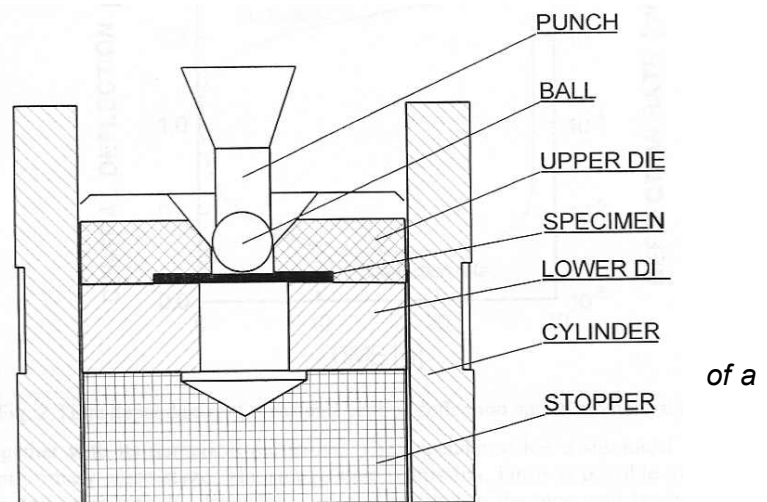

Fig A3.1: Schematic sketch small punch bulge test

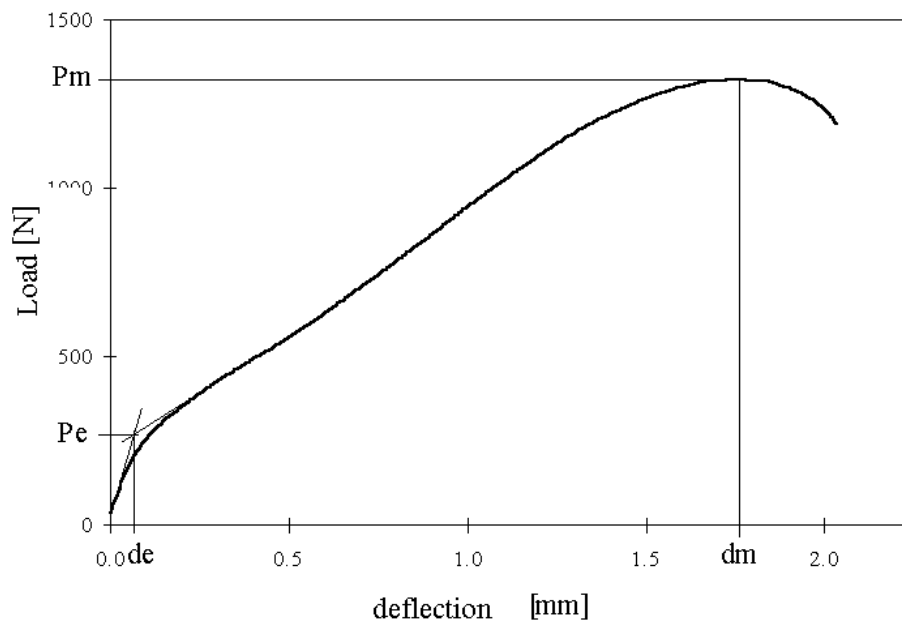

Fig. A3.2: Load-deflection curve of a small punch test

Bulge test - the penetrator is a ball or punch with a hemispherical tip. The material tested is forced into the hole of the lower die up to the point of crack initiation on the top of specimen. Dimensional condition for the Bulge test is:

$$D > d + 2t \quad (1)$$

where D is the hole diameter of lower die, d is ball diameter and t is the thickness of the specimen.

Shear test - the sharper cylindrical punch is punched through the sample; shear deformation is mainly situated in the area of the clearance between the punch and the lower die hole.

The principal problem of small sample testing is to ensure reliable correlation between the results obtained and yield stress or ultimate strength data of conventional tensile tests. Determination is possible by two methods: by the calculation of measured data or by graphical correlation.

For the Bulge test a relationship of this form has been suggested [1, 2, 3]:

$$R_b = \frac{L_b}{2\pi dt \alpha} \quad (2)$$

and for the Shear test:

$$R_s = \frac{L_s - F}{cdt} \quad (3)$$

where R_b is the yield stress or UTS for the Bulge test, R_s represents the yield stress or UTS for the Shear test, α is the contact angle between the ball and the disc, L_b ; L_s are the loads, F is friction load, t is the thickness of specimen, d is the ball or punch diameter, k and c are constants.

For precise calculation of yield point and/or proof stress it is necessary to estimate the contact angle at calculated points (YS or UTS). The contact angle changes when the displacement increases. At the maximum load the contact angle appeared to be approximately 30° . Calculation of Shear test tensile data depends on the friction coefficient between the loaded punch and the tested material. According to published data (e.g. [6]), the friction load varies over a wide range for different metallic materials.

Constant force of penetrating test (CFP)

In contrast to the CRP test, during the CFP test the loading remains constant (provided the changes in the friction angle are neglected). The typical diameter of a small disc is 8mm, thickness 0.5mm, the punch diameter 2.5mm and the diameter of the hole in the lower die is 4mm. Due to the fact that the thin sample is loaded at high temperature, it may be necessary to use a protective atmosphere such as argon. As with creep tests with measured deformation, it is necessary to continuously record the deflection during testing. The typical curve obtained during small punch creep test is shown in Fig. A3.3.

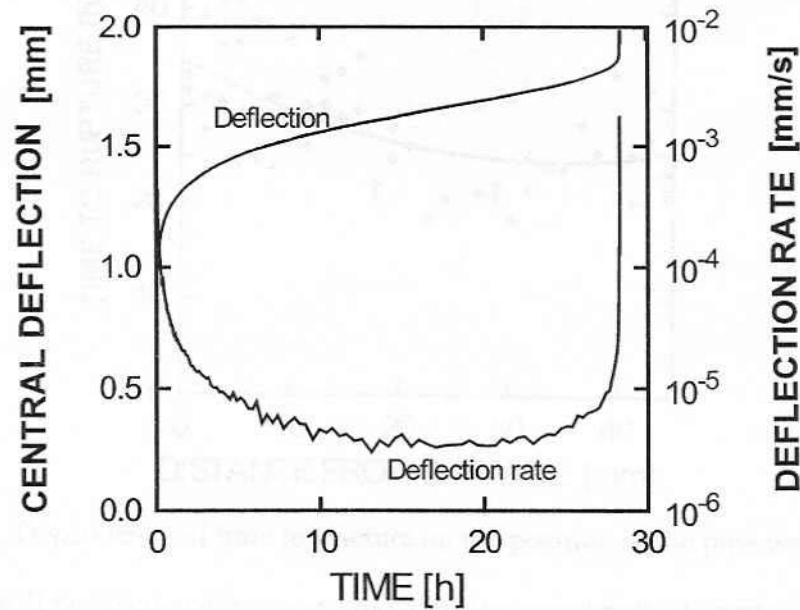

Fig. A3.3: The deflection versus time and deflection rate versus time curve of small sample creep test

The following correlation between creep tests and small punch creep tests has been observed for ferritic low-alloy creep resistant steels:

$$\frac{F}{\sigma} = const \cdot h_0^2 \quad (4)$$

where F is the penetrating force, σ represents the stress in the creep test and h_0 is the thickness of the small sample.

A correlation between rupture elongation and the limiting deformation of a small test can be expressed in the form:

$$\varepsilon_f = \frac{0.08\delta_f}{h_0}$$

where δ_f is the final deflection at the moment of specimen rupture and ε_f represents the corresponding rupture elongation of the creep test.

References

- [1] Lucas, G.E.: Review of Small Specimen Test Techniques for Irradiation Testing. Met. Trans., Vol. 21A, May 1990, s. 1105.
- [2] Purmenský, J.: Review of Small Punch Techniques (Bend Test, Bulge Test and Shear Punch Pest) Materials Dep. of University College, Swansea, May 1991.
- [3] Okada, A. - Yoshie, Y. - Kojima, S. - Abe, K. - Kiritani, M.: The correlation among a variety of miniaturized mechanical tests and their application to D-T neutron irradiated metals. Journal of Nuclear Materials, Vol. 133 + 134 (1985), p. 321.

APPENDIX 4

Schematic Guidance for the Set-Up of a Dedicated Testing Program for Post Exposure Material Creep Properties Determination

V. Kanta [SKODA Czech Republic]

blank page

Appendix 4

Schematic Guidance for the Set-Up of a Dedicated Testing Program for Post Exposure Material Creep Properties Determination **(V. Kanta)**

The present flow-chart has the aim to support the decision making on the set-up of a testing program, heading for creep rupture properties determination for post exposure material.

The chart was kept simple by purpose in order to simplify its use as an overview; nevertheless it is recognised, that actually there are many „small“ here not detailed decisions in A1-A6 and that there could be a need for e.g. additional returns to previous steps, more deals with customer or supplementary assessment loops.

Legend for flow chart of main steps leading to a CTP on PE material

Abbreviations:

PE.. post exposure

CTP.. creep testing programme

CRL.. computation of residual life)

Input data - information:

- i1 Main data about component and customer's requirements; reasons/causes and data used for decision to do CTP+CRL
- i2 Information about creep testing capability (e.g. capacity, equipment, machines for full/miniature size of test bars ...)
- i3 CTP+CRL models (patterns) *
- i4 Information about sampling of material (decided before): location, position, sampling techniques, amount
- i5 Information re sampling of material: equipment and techniques available for sampling, results of NDT
- i6 Detailed information about component and service (e.g. design data, service conditions and time, dimensions of component, creep measurements on component, results of NDT etc. see /1/)
- i7 Information about heat resistance of virgin material
- i8 Information about CTP+CRL made in the past on a similar component.

Actions - work:

- A1 Collection of the main data, work on document D1 that contains a) an overview of main component data and general factors influencing a CTP b) a suggestion of CRL model(s) applicable for the case.
- A2 Work on sampling (inclusive check of component integrity), deal with customer, document D2 worked out, its approving by the customer.

- A3 Work on CRL; document D3 worked out containing brief description of CRL procedure(s) finally suggested.
- A4 Work on CTP for creep tests with strain measurement; document D4 worked out.
- A5 Work on CTP for isotherm tests (to get isotherm curves); document D5 worked out.
- A6 Work on CTP for isostress tests (to get isostress curves); document D6 worked out.

Output data - documents:

- D1 Brief main data survey including:
 - a) main data about component – design and service data.
 - b) requirements on CRL from customer's side (e.g. aim of CRL, costs, time for CRL available ...)
 - c) suggestion of 1 or 2 CTP+CRL patterns applicable for the case. *
- D2 Data about material sampling from component including: location, position, sampling technique, amount of material, who will sample, data about costs and time for sampling if need be; sampling drafted with respect to form, size, number of test bars according to CTP+CRL model suggested before.
- D3 Description of finally suggested CRL method(s) or reference
- D4 CTP for the tests with strain measuring including: form, size, number of the test bars, decision whether the testing will be in air/argon/vacuum, test conditions for every test.
- D5 CTP for isotherm tests including: form, size, number of the test bars, decision whether the testing will be in air/argon/vacuum, test conditions for every test.
- D6 CTP for isostress tests including: form, size, number of the test bars, decision whether the testing will be in air/argon/vacuum, test conditions for every test.

Notes:

- * model (pattern) of CTP+CRL for a component is a draft that is suitable for certain conditions; it includes concrete data e.g. about test bars, test conditions, expected times and further data – description of CRL procedure that uses the creep test results; model is a generalization of a certain way to residual life and is based on practice.
- /1/ ECCC Recommendations Vol. 3, Part III, [Issue 2], 2001: Data Acceptability Criteria and Data Generation: Recommendations for Creep Testing of PE Materials.

Flow chart of main steps leading to a CTP on PE material

